

# Application Of Substitution Schemes For The Method Of Measuring The Humidity Of Bulk Materials

Palvan Iskandarovich Kalandarov<sup>1</sup>, Zieviddin Mamurovich Mukimov<sup>2</sup> Gazieva Rano Teshabaevna<sup>3</sup>, Ubaydullayeva Shakhnoza Rakhimdzhanoyna<sup>4</sup> Alimova Nodira Batirdzhanoyna<sup>5</sup>

<sup>1</sup>Doctor of Technical Sciences, Professor, Tashkent Institute of Irrigation and Agricultural Mechanization Engineers 100000, Tashkent, Uzbekistan

<sup>2</sup>Researcher, Tashkent Institute of Irrigation and Agricultural Mechanization Engineers 100000, Tashkent, Uzbekistan

<sup>3</sup>Candidate of Technical Sciences, Professor Tashkent Institute of Irrigation and Agricultural Mechanization Engineers 100000, Tashkent, Uzbekistan,

<sup>4</sup>Candidate of Technical Sciences, Associate Professor, Tashkent Institute of Irrigation and Agricultural Mechanization Engineers 100000, Tashkent, Uzbekistan,

<sup>5</sup>Doctor of Technical Sciences, Professor Tashkent State Technical University,

Email: <sup>1</sup>eest\_uz@mail.ru, <sup>2</sup>t.automation@tiiame.uz <sup>3</sup>r.gazieva@tiiame.uz, <sup>4</sup>ushr@rambler.ru, <sup>5</sup>nali71@yandex.ru

**Abstract:** The article considers the analysis of a high-frequency humidity meter based on the dielectric method applied to bulk materials on the example of grain. A capacitive method is described where the controlled product is considered as a dielectric filling the converter, and an equivalent circuit of the converter is generalized, which can be represented as an electrical circuit.

The complex permittivity of a nonpolar solid dielectric is analyzed, it is determined by the complex polarizability, and the frequency dependence of the permittivity is determined by the frequency dependencies of the real and imaginary parts of the electronic and ionic polarization, where the metrological and information optimization of the measuring device is described, which reduces to the best allocation of the useful signal.

As a result of the application of the substitution scheme, certain features of the humidity conversion of the output signal of a dielectric high-frequency primary converter arise, which determines a wide, practical continuous spectrum of relaxation time covering the corresponding measurement range.

**Keywords:** high-frequency method, dielectric method, permittivity, humidity, substitution scheme, measurement range.

## 1. INTRODUCTION

In moisture measurement, various types of converters are used to measure the composition of various materials, most of them bulk. For example, in the grain processing industry, moisture meters of bulk granular materials are used. From the variety of methods used in moisture measurement, a specific one is selected, in which the measured physical parameter of the

medium has the closest correlation with the controlled technological parameter, most often it is humidity.

## 2. METHODS AND MATERIALS

High-frequency (dielkometric humidity meters operating in the medium-wave and short-wave ( $f = 0.3-30$  MHz) frequency ranges) measuring systems are widely used, this is due to the fact that the dielectric constant of the material containing moisture has a much greater influence than all other factors.

However, the analysis of a number of literature sources [1, 2, 3] they are called dielcometric, and in others they are called – capacitive humidity meters. But the principle of these methods is the same, they are based on the use of a significant superiority in the value of the permittivity of water and the permittivity of other components in controlled media, both solid and gaseous.

Both meters are capacitive, if we consider their practical implementation, for clarification, we can imagine that they carry out the same conversion algorithm, which can be represented as

$$W_m - \varepsilon_m - C_m - B.$$

Where  $W_m$ ,  $\varepsilon_m$ ,  $C_m$  – respectively, humidity, permittivity, electrical capacitance of the controlled material in the sensor; B is the output value of the device.

Ultimately, the output value is proportional to the measured electrical capacitance of the sensor filled with the controlled material, which in a simplified form for all sensor designs can be represented from [4] by the expression:

$$C_m = \varepsilon_m \cdot K.$$

Where K is the reduced design parameter of the sensor, which depends on the shape and size of both the electrodes and the interelectrode space.

In dielmetric meters of the composition of bulk media installed in technological flows, the sensors are constantly subjected to both physical wear and other types of exposure, which leads to a change in the parameter K. This, in turn, affects the metrological characteristics of measuring devices, which is why it is often necessary to change the sensors and re-calibrate the entire measuring system.

## 3. RESULTS

However, no product can be considered as an ideal dielectric, and therefore the electrical energy supplied to the capacitor converter filled with the product is spent not only on recharging the capacitor, but also dissipates in the form of heat losses in the dielectric. If the controlled product is considered as a dielectric filling the converter, then the equivalent circuit of the converter can be represented in the form of an electrical circuit shown in Fig.1.

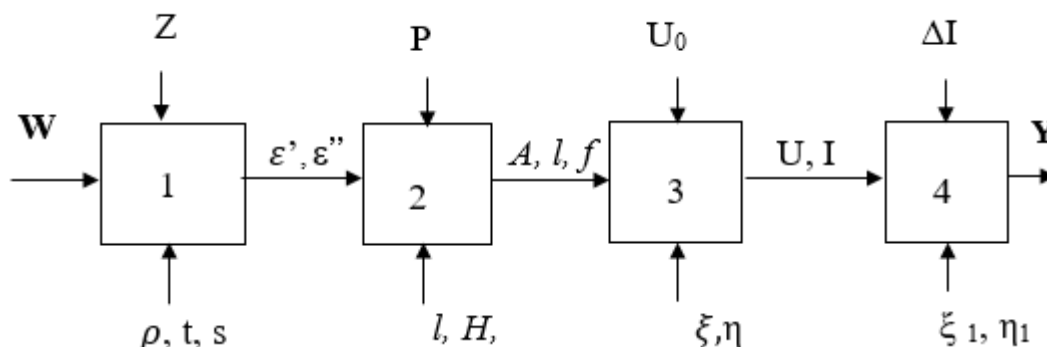

Fig. 1. Block diagram of the measuring converter

To measure humidity, medium- and short-wave ranges (from 0.1 to 50 MHz) of high frequencies are most often used [5]. In the specified range, primary capacitive converters of dielectric monitoring devices can be considered as systems with concentrated parameters.

#### 4. DISCUSSION OF THE RESULTS

The complex permittivity of a nonpolar solid dielectric is determined by the complex polarizability  $\alpha_1$  and  $\alpha_i$ . Accordingly, the frequency dependence of the permittivity will be determined by the frequency dependencies of the real and imaginary parts of the electronic and ionic polarization. It follows from [6] that the real and imaginary parts

$$\tilde{\varepsilon}^* = \varepsilon' - j\varepsilon'' \quad (1)$$

are functions of the attached field and are defined by  $\tilde{\alpha}_1(\omega)$

и  $\tilde{\alpha}_i(\omega)$ : the tangent of the dielectric loss angle  $tg\delta = \frac{\varepsilon''}{\varepsilon'}$ ; complex conductivity

$$\sigma^* = \sigma' + j\sigma''.$$

The dependencies between these values have the form:

$$\varepsilon' = \varepsilon; \varepsilon'' = \frac{\sigma}{\omega}; tg\delta = \frac{\varepsilon''}{\varepsilon'} = \frac{\sigma}{\omega\varepsilon'}; \quad (2)$$

$$\varepsilon^* = \varepsilon(1 - jtg\delta),$$

where,  $\omega$  - is the angular frequency,  $\varepsilon$  - is the permittivity,  $\varepsilon'$  - is the real,  $\varepsilon''$  - is the imaginary component of the permittivity,  $\varepsilon^*$  - is the complex permittivity,  $tg\delta$  - is the tangent of the dielectric loss angle,  $\sigma$  - is the specific conductivity.

Knowing one of the specified parameter pairs, it is possible to calculate any other pair.

Parameters such as the Q-factor of the contour are also used  $Q = \frac{1}{tg\delta}$  or active  $\sigma'$  and reactive  $\sigma''$  components of complex conductivity  $\sigma^*$ .

The practical significance of these results depends on the operating frequency range. According to  $\tilde{\alpha}_1(\omega)$  и  $\tilde{\alpha}_i(\omega)$  they remain equal to the actual values of polarizability as long as the frequencies at which the measurements are carried out lie in the region below the infrared frequencies. Therefore, for the materials under study  $\tilde{\varepsilon}$  up to microwave frequencies is equal to  $\varepsilon'$ , and behavior  $\varepsilon^*$  the same as in the case of a static field [7].

The main process that determines the properties of a real dielectric in an alternating electric field is polarization. In many products, including in solid bulk materials, almost all known types of polarization are observed - electronic, ionic, dipole-relaxation, electrical and structural.

Metrological and information optimization of the measuring device is reduced to the best selection of a useful signal from its mixture with interference.

From [8], the change in the output signal  $Y$  (Fig.1) is described by the equation

$$dy = \frac{dy}{dW} dW + \frac{dy}{dz} dz + \frac{dy}{dp} dp + \frac{dy}{du} du . \quad (3)$$

The purpose of the information system is the best transmission of a useful signal  $(dy/dW)dW$  with maximum suppression of interference described by the other components of the right side of equation (1). Minimizing the error is achieved provided that the sensitivity of the measuring device to changes in humidity  $S_w = \frac{dy}{dW}$  maximum, and the sensitivity to interference  $S_n = dy/dz + dy/dp + dy/du$  - минимальна.

The implementing polarization is determined by the sum of all the types of polarization available in this material. The replacement circuit contains the capacitance between the electrodes in a vacuum and the sum of the capacitances corresponding to different types of polarization. Two features of the humidity conversion of the output signal of a dielcometric high-frequency primary converter follow from the substitution scheme [9]:

a) The output signal always has a complex character, i.e. the total resistance of the primary measuring converter with the material is a complex value. The reactive (capacitive) component of this resistance is associated with the permittivity; the active component is associated with dielectric losses and conduction losses;

b) The dielectric parameters of the wet material depend on the frequency of the field. This is explained by the dependence of various types of polarization on frequency. With increasing frequency, we can expect a decrease in the total polarization due to inertia and other factors. This will correspond to a decrease  $\varepsilon'$ .

Here we can distinguish two areas that differ significantly from each other. In the low-frequency region, the losses are caused by the imposition of a number of effects, the separation of which is very difficult.

With increasing humidity, moisture is distributed not in the form of separate isolated inclusions, but in the form of continuous films, bridges, etc. This leads to a wide, practical continuous spectrum of relaxation time, covering the range from  $10^{-8}$  до  $10^{-3}$  с. [10].

The above-mentioned features of bulk materials must be taken into account when mathematically describing the dielectric properties of the materials under study from their humidity.

## 5. CONCLUSIONS

Based on the performed analysis, for the most effective solution of the problem of using information about the moisture content of grain crops at various stages of the technological process, it is necessary to apply a systematic approach based on a comprehensive comprehensive consideration of the problem, taking into account the internal and external relationships of all its parts (system elements) that are essential from the point of view of solving the tasks set. In this case, the system methodology dictates the expediency of abandoning devices for private use that solve separate disparate tasks that are not related to each other, as is practiced in humidity measurements at most existing enterprises.

It is necessary to create a single unified system that solves all tasks related to obtaining and using information about the humidity of raw materials, intermediate and finished products of the enterprise, starting from laboratory control up to control and automatic control of technological processes and issuing the necessary information to the highest levels of the hierarchy of the automated enterprise management system.

To implement the system, a complex of technical means is required, characterized by information, metrological, operational and other types of compatibility. The most important prerequisites for this are the unification of the output signals of all used primary humidity measuring transducers( sensors), as well as measuring devices. The unification of the output signals of measuring converters is implemented on the basis of the State System of Industrial Devices and Automation Equipment (GSP).

The advantages of such a solution are obvious. The unified system allows you to solve the maximum number of tasks using the minimum number of types of technical means, i.e. it minimizes the redundancy of technical means. This greatly simplifies and facilitates the operation of technical means, their repair and adjustment, training of technical personnel, which is of great importance in the real conditions of enterprises of the agro-industrial complex.

## 6. REFERENCES

- [1] Dmitriev D. A., Fedorov N. P., Fedyunin P. A., Rusin V. A. Surface waves and microwave devices for monitoring electrophysical parameters of magnetodielectric coatings on metal /Edited by N. P. Fedorov. - M.: "Publishing House Mashinostroenie -1", 2004. -190 p. (In Russ.)
- [2] Fraden J. Handbook of Modern Sensors: Physics, Designs, and Applications. Springer New York, 2004. DOI: 10.1007/b97321 (Russ. ed.: Fraden J. Sovremennye datchiki: Spravochnik. Moscow, Tekhnosfera Publ.,2006. 592 p.).
- [3] Sergienko A.B. Digital signal processing. St. Petersburg, Piter Publ., 2002. 608 p. (in Russian).
- [4] Galushkin S. S. Dielkometrichesky moisture meter of bulk media. St. Petersburg, 2008. Notes of the Mining Institute. vol. 178. pp. 130-134. (In Russ.)
- [5] Kalendarov P. I., Iskandarov B. P., Physicochemical measurements: measurement of the moisture content of brown coal from the Angrensk deposit and problems of metrological assurance. *Measurement Techniques*, 2012, vol. 55, no. 7, pp. 845–848. <https://doi.org/10.1007/s11018-012-0049-1>
- [6] Iskandarov B.P., Kalendarov P.I. An analysis of the effect of interfering factors on the results of measurements of the moisture content of a material at high frequencies. *Measurement Techniques*. 2013. T. 56. № 7. C. 827-830.
- [7] Kalendarov P. I., Logunova O. S., Andreev S. M. Scientific bases of moisture measurement / Tashkent, 2021. 174 p. (In Russ.)
- [8] Ismatullaev P. R., Kalendarov P. I. Ultrahigh-frequency moisture measurement and problems of metrological support. *Instrumentation*. 2011. No. 7 (133). pp. 40-44. (In Russ.)
- [9] Kalendarov P. I., Iskandarov B. P. Humidity control devices for automation of technological processes of production of the agro-industrial complex. *Automated technologies and production*. 2013. No. 5. pp. 179-184. (In Russ.)
- [10] Kalendarov P.I., Mukimov Z.M., Logunova O.S. Anaiysis of hydrothermal features of grain and instrument desulphurization of moisture control. *Technical Science and Innovation*. 2020. № 1. C. 117-123. (In Russ.)