

Inter Combining Quazi Z Source Network With Matrix Converter For Wind Powered Distribution System

Dr.T.Baldwin Immanuel¹, Mr.P.Rathnavel², A.Suresh³, K.Manikandan⁴

¹Associate Professor, Department of EEE, AMET University, Chennai

²Assistant Professor, Department of EEE, Sri Sairam Institute of Technology, Chennai

³Professor, Department of Marine Engineering, AMET University, Chennai

⁴Assistant Professor, Department of EEE, AMET University, Chennai

Abstract

This paper proposes a Permanent Magnet Synchronous Generator (PMSG) based wind energy conversion system (WECS) having combination of Quazi z source network with matrix converter to raise the output voltage in accordance with load requirement. This combination is formed by cascading quazi Z source with direct matrix converter. Whenever the speed of wind mill varies, the direct matrix method will take part in regulating out in the form of varying duty ratio. It is having capability to perform buck-boost operation in addition with concentration upon duty ratio and bidirectional power flow controllability. Further this method having several advantages such as accommodates less number of active and passive components, more reliable, efficiency is said to high, etc. The particular reason for choosing proposed conversion method is deduction in size of filtering unit rather than preceding method. To validate its efficiency, the proposed topology is simulated and overall functioning is presented in the form of waveforms.

Keywords: Permanent Magnet Synchronous Generator (PMSG); Quazi Z Source Converter (QZSC); Matrix Converter; Duty Ratio; Reliable; Efficiency.

1. INTRODUCTION

Loss of power due to transmission, increase in productivity cost and raise in use of fossil fuel makes renewable energy would be a better choice for generating sustainable voltage. Renewable energy available for continuous power generation is solar, wind, tidal, hydro, geothermal, etc. From this wind energy is chosen due to its availability and higher productivity within a short term, durability, and several other economic benefits. WECS based DC micro grid gains more attention due to its features and they are: able to conduct lossless generation and transmission; availability of abundant renewable energy in a particular sector will make the surrounding to make it easily available; less capital cost. Apart from generation, the processing of gained voltage is essential factor. Thus semiconducting devices play a vital role in rectification and conversion methodology. Rectification won't cause any difficulties in supply system. To concentrate upon DC-DC is must. The above said topology can have enough potential to strengthen the output. Improving magnitude in addition with satisfying load is necessity. So that, a special care upon choosing these terms is mandatory. Conventional method adopts high rated step-up transformer and large filtering unit for delivering constant voltage towards load. Mismatching of frequency tend to be high due to its operation under variable operating condition. For incremental action and concentrate upon power quality, the selection of converters will be a better choice. By these, converters are

designed with simple in structure, robust, more effective and low cost [1]. To raise the gain other than conversion, a selection of generators is must. Then PMSG is selected and it maximise the outlet in proportion with load necessity. Then fuzzy logic control technique is presented to utilize variable wing blown on turbine shaft; also it maintains stable voltage at DC link capacitor which will makes the entire system functioning in an appropriate rate. This in turn makes feedback from inductor motor is continuously observed and taking it as reference to generate gate pulse for switches intruded in DC-AC. By this, switches are operated at desired frequency [2]. The following structure describes principle behind processing and operation of generating electricity from WECS mechanism and power injection towards grid.

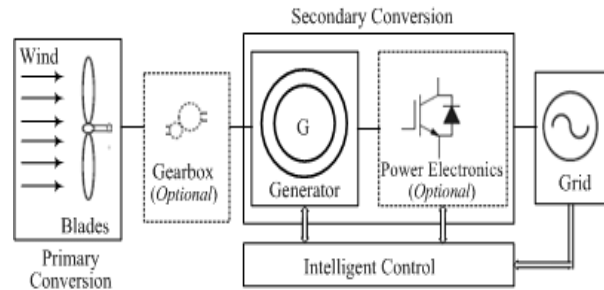
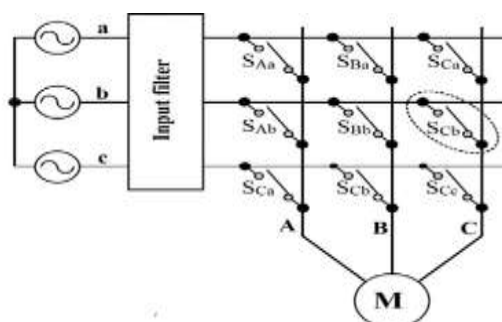

Figure 1 Basic of WECS

In [3] PMSG is chosen due to absence of gear box which eliminates torsional stiffness problems; also reduction in size, weight and compact structure are additional advantages of PMSG. Intruding z source inverter is presented to bring maximum power from source and drain it towards load. It would deal with eliminating harmonics and current ripple. DC link voltage control is additional key features. In continuation with voltage control, reduction in ripple voltage across capacitor is prominent one. Through improved PWM strategy, the above statement is possible. Rearranging shoot through time of active and zero state in impedance network avoids complexity on charging state of capacitor. Presence of sustainable power flow across capacitor is the only solution to maintain constant output voltage [4]. Deciding input to converter, rectification is considered as first and foremost stage. The functioning of semiconducting devices present in it interrelates with switching cycle. To deal rectification and voltage conversion, current source control is preferred. This would be a better choice [5]. To bring brief notes about control strategy space vector modulation control is presented in respect to improving the voltage is displayed in [6]. Other than control logic, conversion topologies are responsible for raising the productivity in case windblown across blades is slightly decreased. For this quazi Z source inverter is chosen as attractive solution to compensate necessity.

By relating quazi z source network with fuzzy logic control maximize the output in the form of reducing harmonics and severe short circuit faults. Other than wind, the above mentioned converter is preferred for variable speed drives and electric vehicles. In between load and source other than rectifier back-to-back converters are has become more popular in conventional method. It holds number of active and passive components; it is said to be more complex in nature (.). In order to avoid uncertainty, matrix converter is designed and enrolled within transmitting rectifier outlet to load. Rather than predecessor, it neglects unnecessary filtering unit and DC link capacitor. Some of the advantages are input power factor controllability, compact structure. It is categorized into types: direct and indirect method. Both have adequate capability to do voltage and current conversion. Number of stages took for conversion is the only difference between two methods. Direct method conversion

method adopts single stage processing. Then this will be a right choice for functioning under differential circumstances. The switches present in it accommodate hysteresis control. Both reactive power and speed are controlled through closed loop structure. The performance of matrix converter is higher than that of conventional method is experienced in [7-8]. The change of controller will cause some variation in outlet which determines the efficiency respectively. Some controllers are selectively chosen to resolve harmonics and ripple. Likewise previous one, voltage source inverter is integrated with matrix converter in [9]. In next stage fuzzy logic control is suggested to withdraw a higher order magnitude is specified in [10].



(a) Direct matrix converter

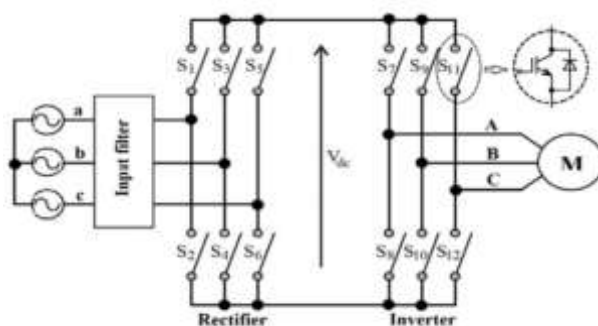

(b) Indirect matrix converter

Figure 2 Representing detailed structure of matrix converter

From several researches it is evident that interaction of quazi z source network with matrix converter will promote sustainable power supply without unusual power flow and interrupts. The choice of generator depends upon capability to fulfill the requirement. In acceptance with that statement, PMSG is chosen. The diode bridge rectifier neglects back-to-back connection; in that several components needed in conventional method are eliminated. PMSG does not need dc excitation for generating magnetic field. Absence of slip ring and brushes, the structure becomes compact.

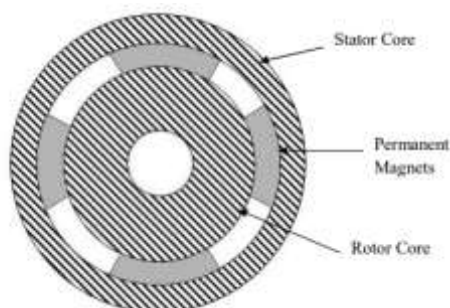

Figure 3 Structural analysis of PMSG

2. PROPOSED TOPOLOGY

The following structure describing about single phase proposed converter. Likewise conventional Z source network, it possesses dual inductor and capacitor; but it contains a bidirectional switch which controls whole action with respect to switching frequency.

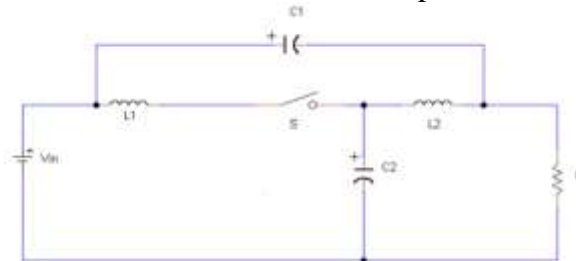

Figure 4 Proposed quazi z source converter

The converter performs buck/boost operation in relation with duty ratio and load. To operate under continuous conduction mode, inductor plays a major role in it. Shoot through problem is relatively low. Switching frequency resizing passive filters used within it.

The below block diagram visualizing process behind generation, transmission and distribution in proposed system. A variable speed accepting PMSG based WECS is interfaced with proposed converter by means of converting generated AC into DC by rectifier.

A breakthrough in voltage limitation is accompanied with it. The output of the matrix converter is delivered towards transformer. The transformer supplies power to the grid.

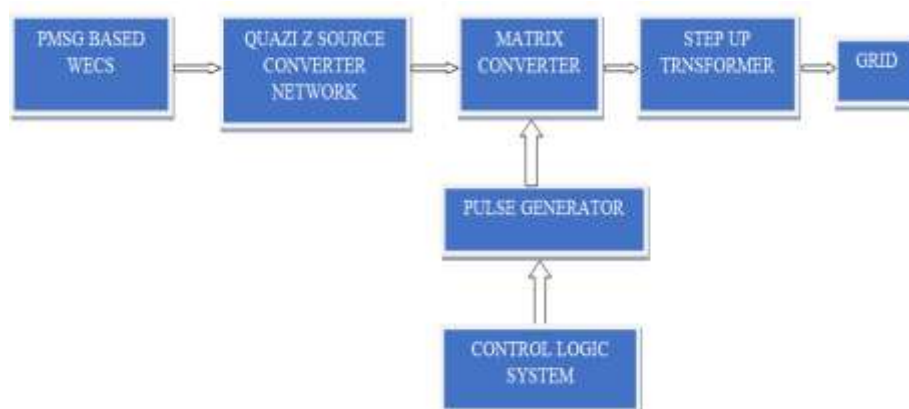

Figure 5 Blocks denoting proposed methodology

3. RESULT AND DISCUSSION

The simulation of the proposed system has been done using MATLAB Software. Especially, Simulink library is used to develop the model as per the topology mentioned in previous section. The differential equations are progressed through fixed step solver. The simulation circuit consists of mathematical modeling of wind energy system based on permanent magnet synchronous generator, matrix converter designed with nine bidirectional switches, three phase electrical load, measurement blocks and scopes.

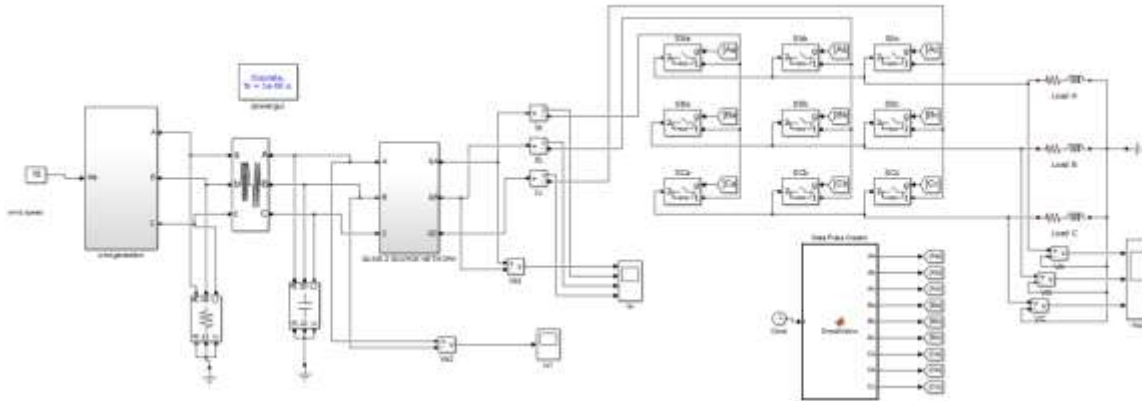
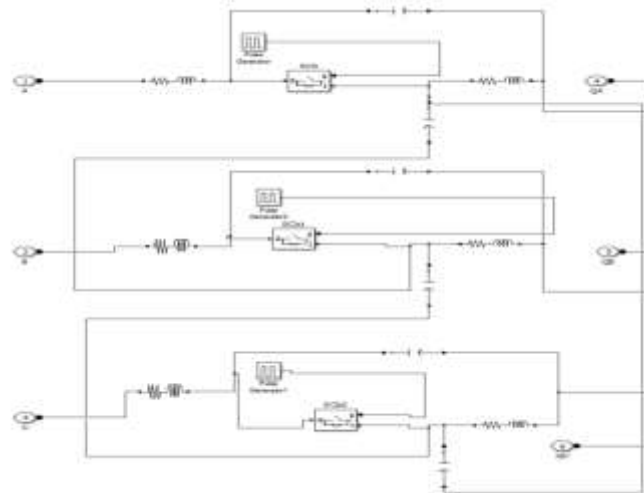

Figure 6 Proposed MATLAB layouts



The structure of three phase quasi Z source network is presented in it. Once it reviews elements arrangement and functioning in a simpler manner by the way of circuit.

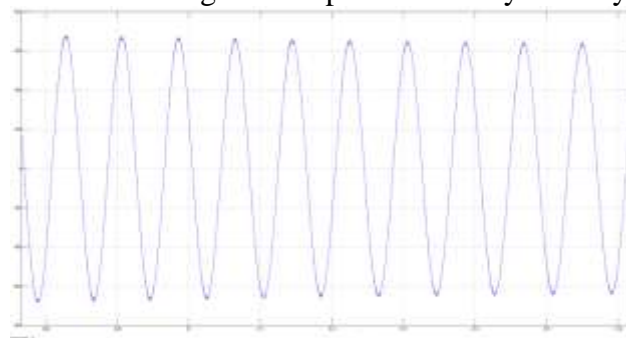

Figure 7 Outputs of WECS

The renewable energy sources are variable in nature and it has less capability to produce high voltage as per the grid requirement. The magnitude of the voltage produced from wind energy system with DC-DC converter is approximately 620V which is shown in figure 7. Each phase having different current and voltage range; it depending upon the delay angle and other key factors. By taking two phases as input to voltage measurement block and output voltage of quasi Z source converter is visualized in figure 8.

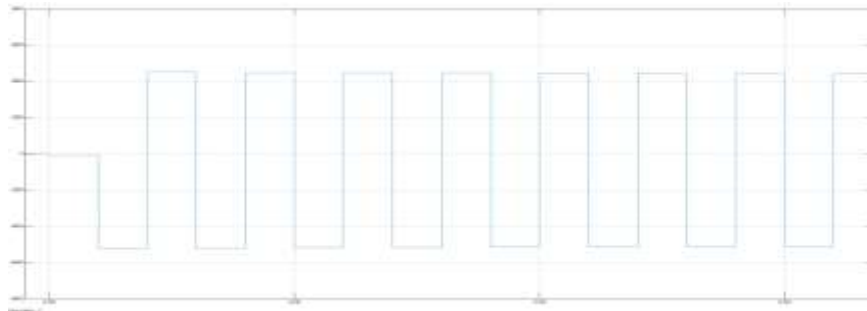

Figure 8 Output voltage of proposed converter

The output of proposed converter will be taken as input to matrix section and below figures plotting current flow.

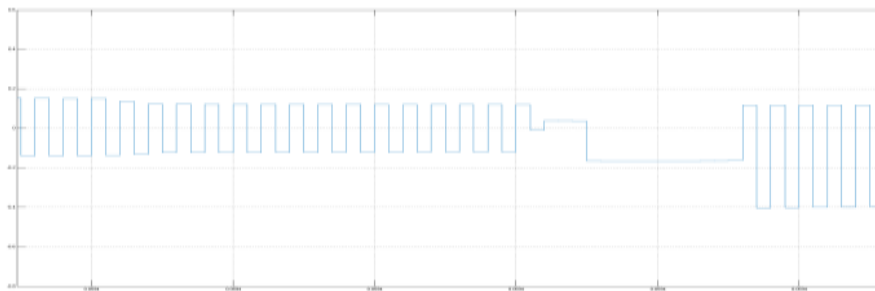

Figure 9(a)

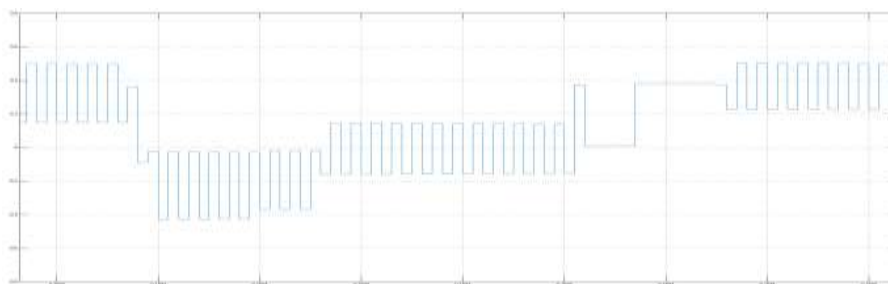

Figure 9(b)

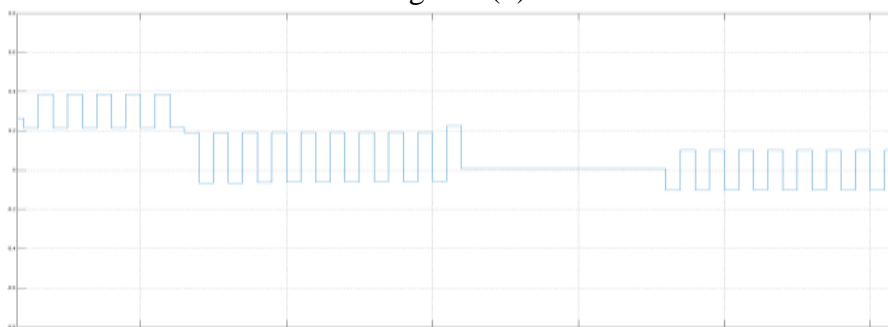

Figure 9(c)

Figure 9 Current flow through each phase of proposed converter

- (a) Ia
- (b) Ib
- (c) Ic

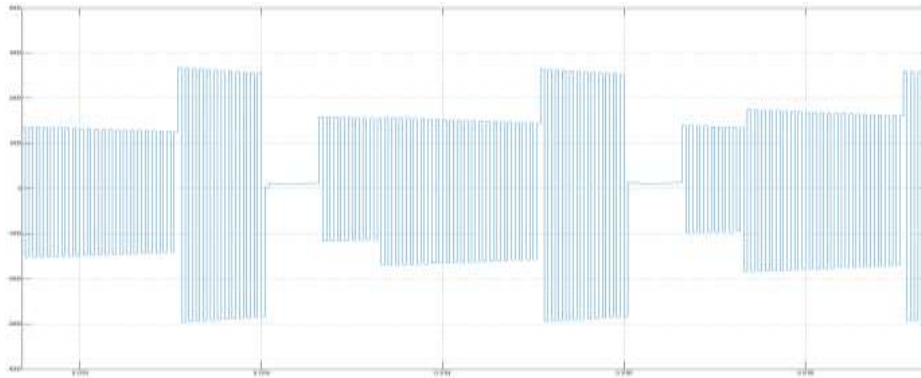

Figure 10 (a)

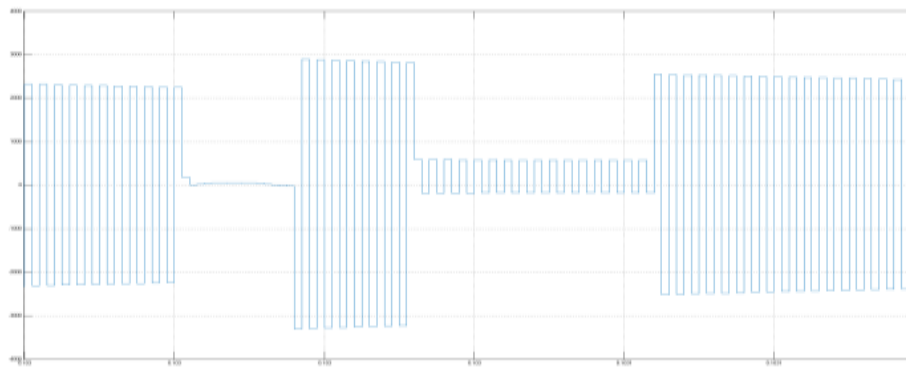

Figure 10(b)

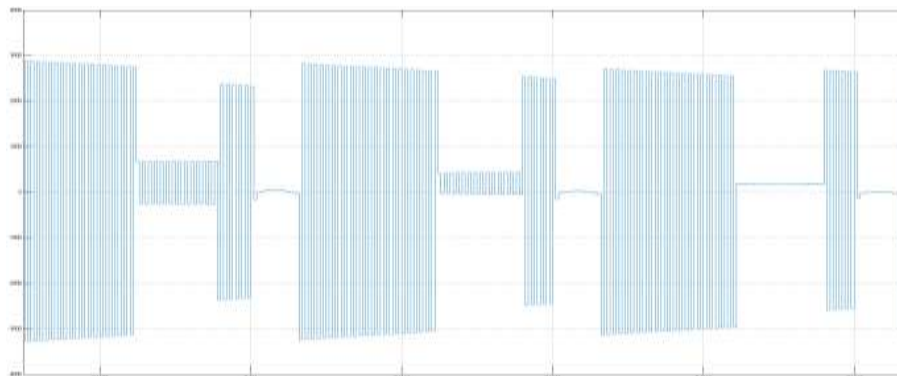

Figure 10(c)

Figure 10 Representing calculated voltage delivered towards load

- (a) V_a
- (b) V_b
- (c) V_c

From figure 11, load flow analysis is presented and the output tends to be 3000V. it is much more greater then outlet of quazi z source converter. To estimate overall performance, the below table is prepared.

	Conventional method	Proposed method
V_{WECS}	140V	620V
V_{dc}	100V	420V
V_{OUT}	4000V	1200V

From above figure it is clear that this method should adopt load necessity and took part in fulfill the requirement with lower duty ratio and switching frequency.

4. CONCLUSION

The matrix converter has been implemented successfully to control the output voltage for different wind speed. The Quasi Z-source inverter was incorporated further on matrix converter in order step up and avoid shoot through effect. The matrix converter was acted in between Generator and electrical grid in order to match the voltage and frequency between them. The Proposed system has been modeled using MATLAB/SIMULINK. The simulation results were helped to validate the proposed matrix converter for wind energy conversion system.

5. REFERENCES

- [1]. Md Rabiul Islam, Youguang Guo, J.G. Zhu, "Power converters for wind turbines: Current and future development", August 2013
- [2]. L.Benaouinate, M.Khafallah, D.Voyer, A.Mesbahi, T.Bouragba, "Nonlinear Control Based on Fuzzy Logic for a Wind Energy Conversion System Connected to the Grid", International Journal Of Renewable Energy Research, Vol.10, No.1, March, 2020
- [3]. Seyed Mohammad Dehghan; Mustafa Mohamadian; Ali Yazdian Varjani "A New Variable-Speed Wind Energy Conversion System Using Permanent-Magnet Synchronous Generator and Z-Source Inverter"; IEEE Transactions on Energy Conversion (Volume: 24, Issue: 3, Sept. 2009)
- [4]. R Dorothy, T.Sasilatha," Smart Grid Systems Based Survey on Cyber Security Issues", Bulletin of Electrical Engineering and Informatics,vol.6.no.4,pp. 337-342,2017.
- [5]. G. Jegadeeswari, K. Kanagaraja, B. Kirubadurai, "Optimization of Gas Turbine Blade Cooling System" at International Journal of Innovative Technology and Exploring Engineering (IJITEE), September 2019/ Volume 8, Issue 11, Pg.no: 4176- 4148.
- [6]. C Gnanavel, T Baldwin Immanuel, P Muthukumar, Padma Suresh Lekshmi Kanthan , " Investigation on Four Quadrant Operation of BLDC MOTOR Using Spartan-6 FPGA," International Conference on Soft Computing Systems,2018,pp. 752-763,2018
- [7]. Mutharasan Anburaj; Rameshkumar T; Ajitha Anburaj; "Wind Energy Conversion Based on Matrix Converter", July 2014; International Journal of Power Electronics and Drive Systems
- [8]. Suman Mondal and Debaprasad Kastha, "Improved Direct Torque and Reactive Power Control of a Matrix Converter Fed Grid Connected Doubly Fed Induction Generator", IEEE TRANSACTIONS ON INDUSTRIAL ELECTRONICS, 2015
- [9]. Gayatri Mohapatra, Asim Kumar Dey, "Control of a PV integrated multilevel Inverter Fed with Matrix Converter", July 2018 - (ICRIEECE)
- [10]. G Jegadeeswari, (2019)"Performance Analysis of Power Quality Improvement using Shunt Active Power Filter" International Journal of Recent Technology and Engineering (IJRTE), 7 (5), 1-3

- [11]. T.Baldwin Immanuel, P.Muthukumar, M.Rajavelan, C.Gnanavel, N.Veeramuthulingam, “An Evaluation of Bidirectional Converter Topologies for UPS Applications” International Journal of Engineering and Technology, Vol. 7, no. 33, pp. 1305-1309, 2018.
- [12]. T.Baldwin Immanuel, P.Muthukumar, C.Gnanavel, M.Rajavelan, M.Marimuthu, “Transformer less single phase Inverter for Grid Connected PV System with an Optimized Control” International Journal of Engineering and Technology, Vol. 7, no. 34, pp. 217-220, 2018.
- [13]. T.Baldwin Immanuel, A.Suresh, M.R.Radhami “Resonant Filter for Photovoltaic Applications” International Journal of Pure and Applied Mathematics, Vol. 119, no. 7, pp. 393-405, 2018.
- [14]. C.Gnanavel, M.Rajavelan, P.Muthukumar, T.Baldwin Immanuel, “A Performance Investigation of a Single Phase Multilevel Inverter Fed Nonlinear Loads for Solar PV Applications” International Journal of Engineering and Technology, Vol. 7, no. 24, pp. 388-391, 2018.
- [15]. T.Baldwin Immanuel, P.Rathnavel, M.Rajavelan “PV fed Seven-Level Inverter using Fuzzy Control Technique” International Journal of Engineering and Advanced Technology, Vol. 9, no. 2, pp. 4102-4106, 2019.
- [16]. A.Suresh, P.Ramesh, S.Prakash, R.Dhanasekaran, “Controllers for handling three phase grid faults in voltage source converter based HVDC transmission system” International journal of advanced science and Technology, Volume 29, Issue 5s, pp:190-200, 2020.
- [17]. S.Prakash, A.Suresh, B.Arulmozhi, “Output voltage regulation of modular multilevel converter used for HVDC transmission” Journal of xi'an university of architecture & Technology, Volume 12, Issue 3, pp: 1701-1704, 2020.
- [18]. M.Geethalakshmi, N.Jayapal, D.Jency Remina, S.Ramya, M.Rajavelan “Wearable ECG Monitoring By Using IOT for Medical Applications” Journal of TEST Engineering & Management (ISSN: 0193-4120) Volume March 2020.
- [19]. K. R. Sugavanam, Dr. M. Rajavelan, M. Prabu, Dr. J. Prakash, M. Malathi, S. Senthilkumar “ BLDC Drive Speed Control with Quasi Z-Source Inverter Using back EMF Estimation Control” Journal of TEST Engineering & Management (ISSN: 0193-4120) Volume May 2020.
- [20]. C. Gnanavel, P. Sathish Khanna, M. Rajavelan, K. Vanchinathan, C. Gokul “Real Time Monitoring and Controlling of Boiler Drum Parameters using Internet of Things (IoT)” Journal of TEST Engineering & Management, Vol. 82, pp. 2195-2198, 2020.
- [21]. R.Sundar, C.Gnanavel, P.Muthukumar “A Unique Single Source Nine Level Inverter with Reduced Switching Devices for Single Phase AC Applications” International Journal of Engineering and Advanced Technology, Vol. 9, no. 2, pp. 4098-4101, 2020.
- [22]. Surya P, Arunachalaperumal C, Dhilip Kumar S, Manikandan K “Design of Parallel Pipelined DIF- FFT Architecture” Journal of TEST Engineering & Management, Vol. 82, pp. 2210-2213, 2020
- [23]. K.Manikandan, A.Sivabalan, R.Sundar “A study of Landsman, Sepic and Zeta Converter by Particle Swarm Optimization Technique” 6th International Conference on Advanced Computing & Communication Systems, IEEE Xplore, 2020.