

# Comparision Of Fuzzy Logic And Pid Controller In Non-Linear System Using Matlab

Aravindaguru I<sup>1</sup>, Pugazhenthithi C<sup>2</sup>, Porselvi S<sup>3</sup>, Ramya P<sup>4</sup>

<sup>1,2,3,4</sup>Department of Electronics and Instrumentation Engineering, M.Kumarasamy College of Engineering, Thalavapalayam, Karur.

Email: <sup>1</sup>aravindagurui.eie@mkce.ac.in

**Abstract - In this project we use Fuzzy logic controller and PID control in the non-linear system using MATLAB. The PID controller controls process variables such as temperature, pressure, speed, flow, etc. We have used a round tank because it has better solid waste disposal, easier mixing, and a complete flow of non-liquid chemicals such as industrial liquid. However, in the task of controlling at the level of the circular tanks, the PID failed to provide a quick response due to inconsistencies in the system. To overcome this regression we use a standard system controller called Fuzzy Logic Controller.**

**Key Words: Conical tank system, PID Controller, non-linear system and Fuzzy Logic Controller**

## 1. INTRODUCTION

Process tank, composition plays an important role in building regulators. We are looking at a round tank for the following benefits such as better solid waste disposal, easier mixing, and complete absorption of liquid chemical industrial liquid. The controller should be selected according to its non-linearity. In the round tank the line variance is due to its diversity in the short term. The quality control of a circular tank is a daunting task and needs to be done in real time. However, in the task of controlling the level of circular tanks, the PID failed to provide a quick response due to the inequalities in the system. To overcome this regression, we use a standard system controller called Fuzzy Logic Controller. A controller designed to use abstract concepts using human thinking that is programmed into complex language. As a result, the water tank system could actually drain more quickly than it fills. As a result, water pressure in housing neighborhoods is inadequate to maintain water distribution. Alternatively, controlling the movement between system components under different loads can reduce overcrowding. To control the flow beyond a certain point, the open valve can be opened or closed. The basic concept remains unchanged, and the changes will be made in accordance with the design expectations. Due to a certain amount of piping diameter, the tank discharges much less than it is filled, which is an interesting feature of this water tank system. The expected output from the input can be set prematurely according to the set rules by trying to check the system in this simulation area. The use of a MATLAB card is vital for merging software components with computer hardware, but the cost of a MATLAB card is incredibly expensive. This project focuses on software simulation only. Fuzzy thinking is a way of more valuable ideas dealing with thoughtful thinking than straightforward and straightforward. The

abstract concept has been broadened to include the concept of partial truth, in which the true value can be anywhere between absolute truth and absolute falsehood. In a broad range of areas from control theory to artificial intelligence, fuzzy logic could be used. Incomprehensible logic quickly rose to prominence as one of today's most successful technologies for developing complex control systems.

## 2. PROJECT DESCRIPTION

### CONICAL TANK

Conical tank is non-linear in nature due to its differing cross sectional area. For enterprises utilizing non straight cycles the regulator configuration is a difficult task, because dominant part of the control hypothesis manages direct interaction. Numerous businesses utilize relative regulator (PI) and corresponding essential subordinate regulator due to its basic design and simple tuning. They are ideal control for direct cycle. Tuning of the regulator is setting the relative, essential and subordinate steady to oversee the interaction. The tapered tank is exceptionally non straight

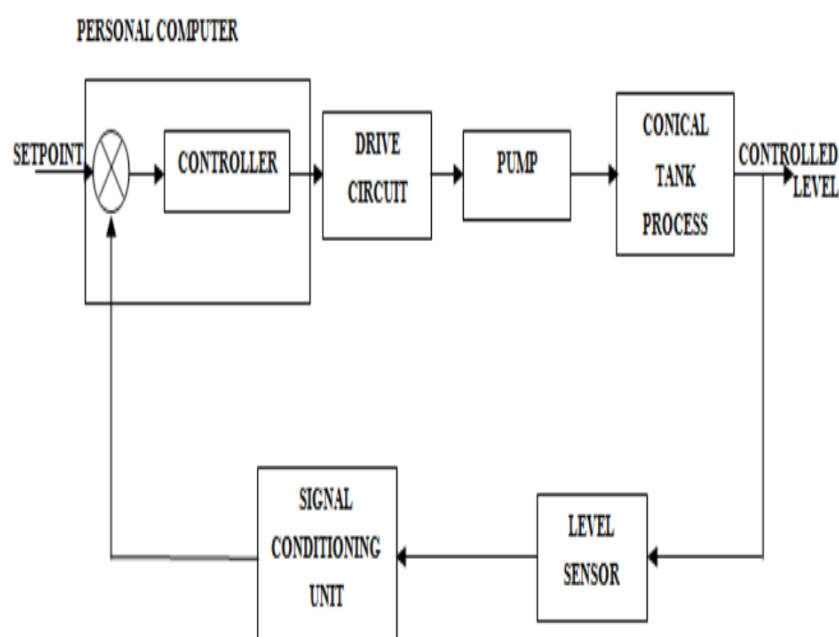

Figure-1: Block Diagram Of Conical Tank System

### PID CONTROLLER

Frequency control system (regulator) is a control framework utilized regularly in modern control frameworks, which is a restricted control system(PID control). The "mistake esteem," as the distinction between assessed measure estimations and the setpoint you need, is determined constantly by the PID regulator The regulator attempts to diminish the blunder over the long haul, with another worth controlled by the heaviness of the control component by setting the variety controls like the situation of the control valve, damper or force provided by the component:

$$u(t) = K_p e(t) + K_i \int_0^t e(\tau) d\tau + K_d \frac{de}{dt}$$

where, again, all that is not wrong, defines the coefficients of equal, cohesive, and occurring terms, respectively (sometimes defined by P, I, and D). In this model, the P corrects the current error values.

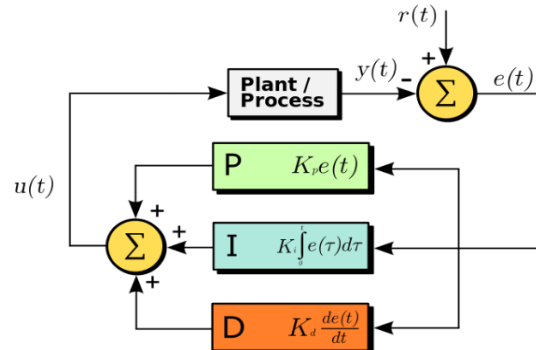

Figure-2: Block Diagram of PID Controller

### FUZZY LOGIC:

Unconventional controls area unit wide utilized in industrial controls, particularly in things wherever typical management style strategies area unit tough to implement. variety of unambiguous rules area unit vital within the use of unsure time management. This paper proposes a unique approach known as block based mostly fuzzy controllers. This analysis is driven by the growing demand within the business to style reliable, economical and affordable controllers[13][14]. The unlockable managerial created of blocks is formed of many controllers with imprecise rules for acting control tasks. The performance of the raw filter is investigated and compared with those found within the normal filter. For this reason, the dc vehicle condition management downside is most well-liked and therefore the vector-controlled vehicle speed management downside. With low pc interference, simulation results indicate that the projected opposing managements with success control the system. Uncontrolled management has gained abundant interest in recent years. several booming applications are reportable within the literature and these applications for incomprehensible controls in industrial processes typically turn out higher results than those of recent controls. the look of the irrational system isn't supported a mathematical modeling model. The refined controls designed to use the abstract thought use human thinking organized for membership activities, abstract rules and therefore the interpretation of rules. The irrational management logic seventeen includes four main categories: fuzzification, base, abstract thought mechanism and defuzzification. Fuzzification and defuzzification phases area unit needed so as to convert and reverse real-world signals into ambiguous and the other way around values. The thinking machine determines an equivalent quantity of incorrect current input in relevance every rule and determines that rules ought to be removed in step with the input field[15][16][17]. Next, unemployed laws area unit compiled to make restrictive actions. Uncontrolled controls area unit able to create effective selections supported language information[18-21]. Recent advances in abstract thinking offer variety of effective ways that to create and maintain uncontrolled management. several of those developments scale back the quantity of imprecise rules. as a result of the employment of advanced managements needs an outsized quantity of your time to calculate every step time to calculate the suitable quantity of control to be utilized in the system. Therefore, the reduction of an outsized base of low cost rules is critical. many studies are studied to cut back the idea of ambiguous rules in texts.

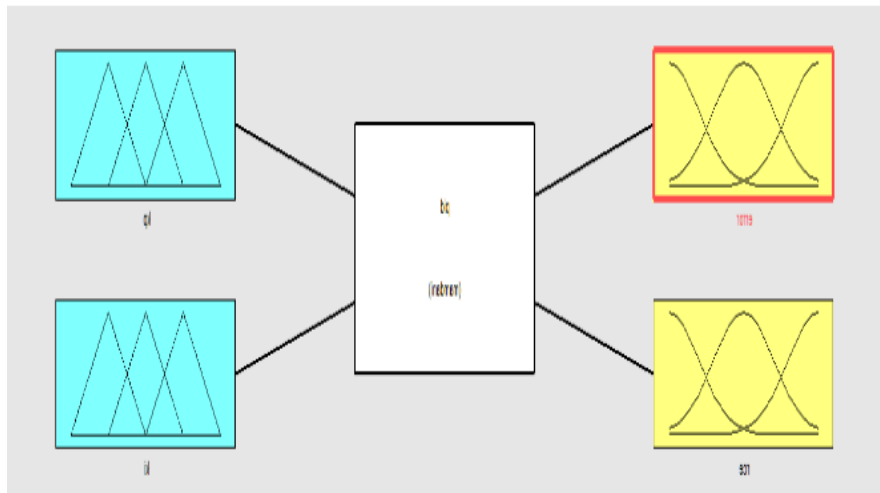

Figure-3: Simulink Of Fuzzy Logic Control

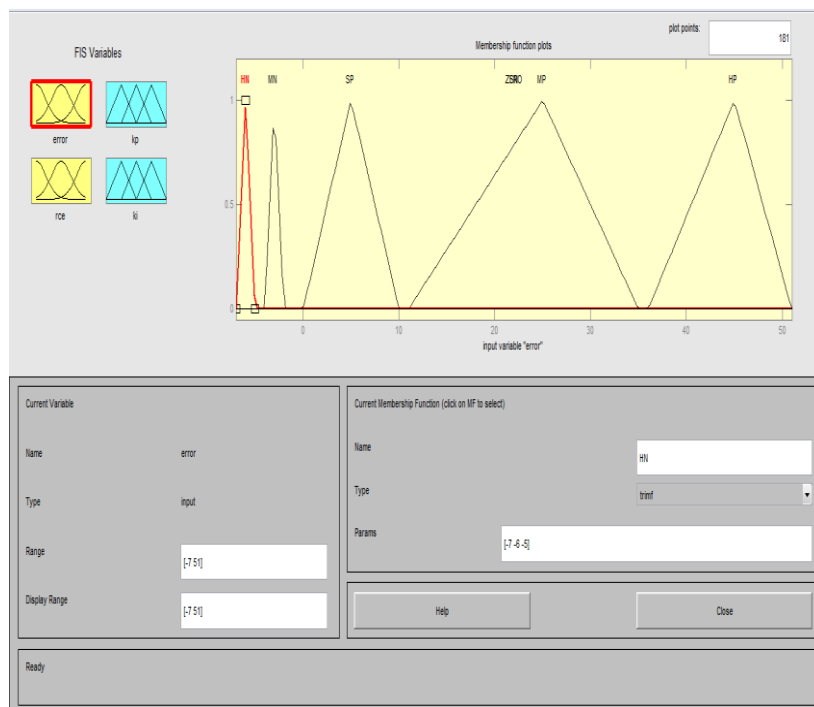

Figure-4: Membership function of the First Input Variable

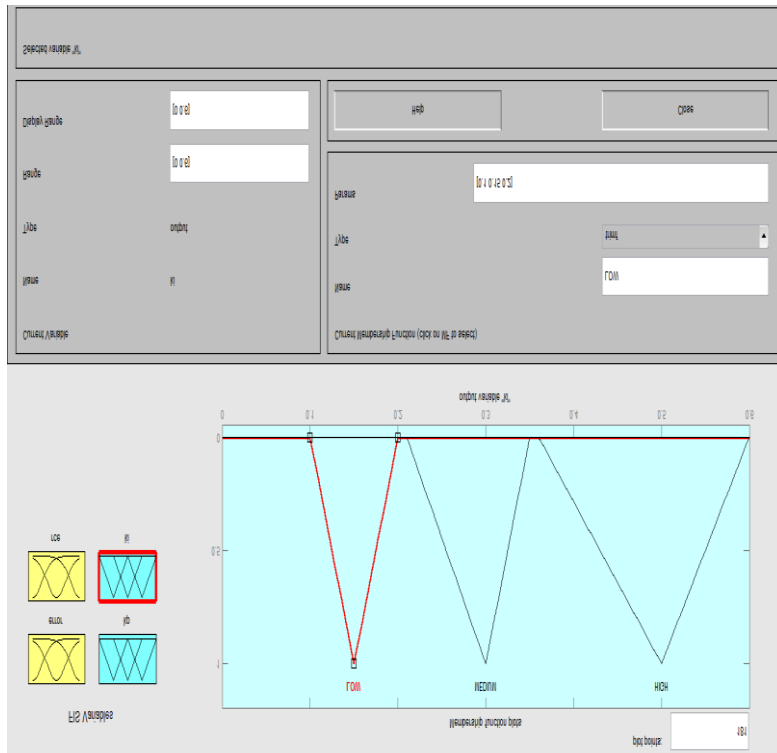

Figure-5: Membership function of the Second Output Variable

### 3. RESULTS AND DISCUSSION:

A simulink model for Conventional (PID) Controller and fuzzy logic controller for liquid level control.

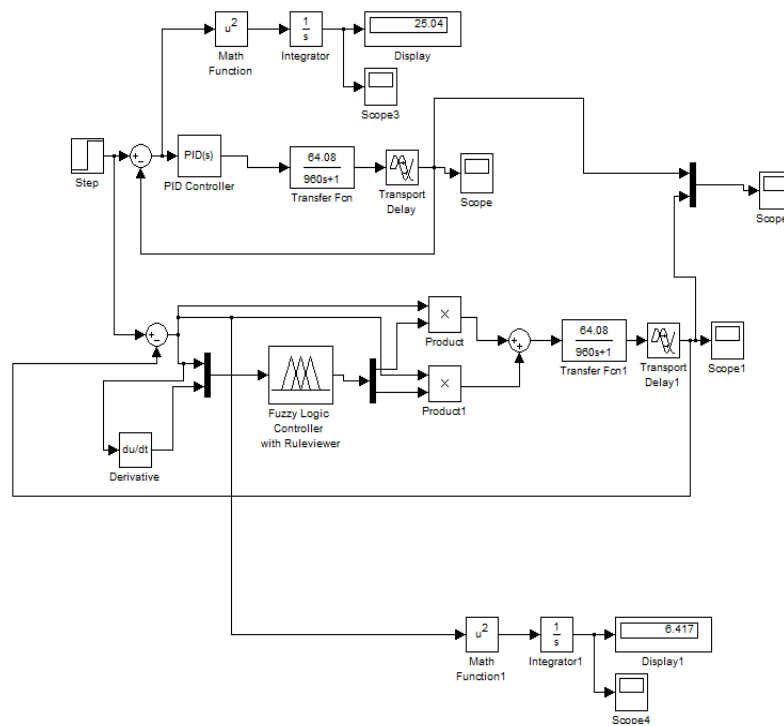

Figure-6: Simulink Model by Using PID Controller and Fuzzy Logic Controller

### SIMULATION RESULTS

Response of Liquid Level Controller using PID Controller and fuzzy logic controller.

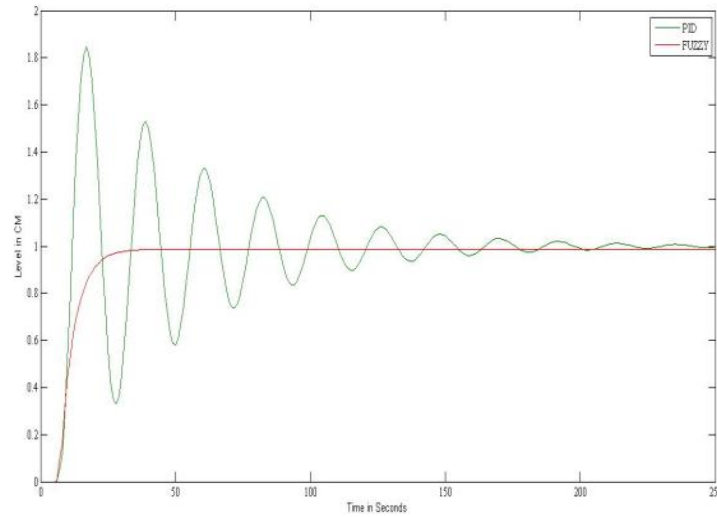

Figure-7: Graph of Fuzzy Logic Controller And PID Controller

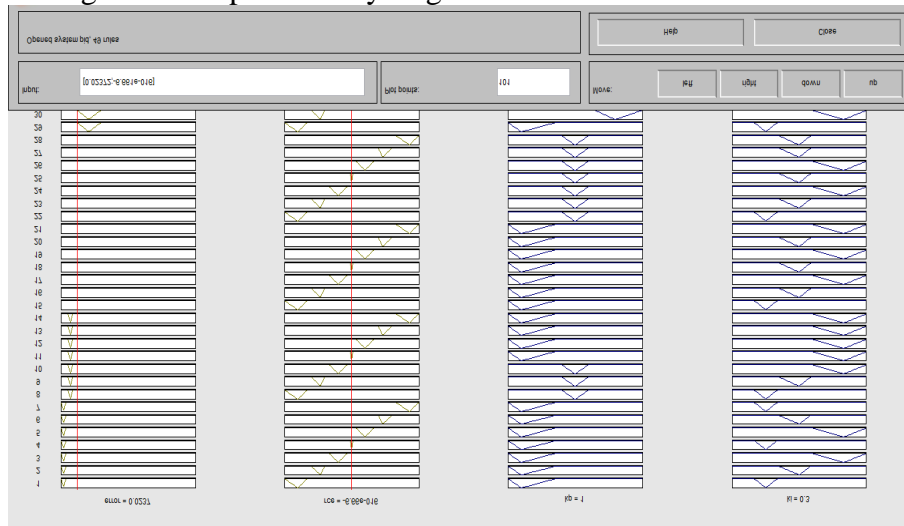

Figure-8:Fuzzy Logic Controller Using Rule Viewer

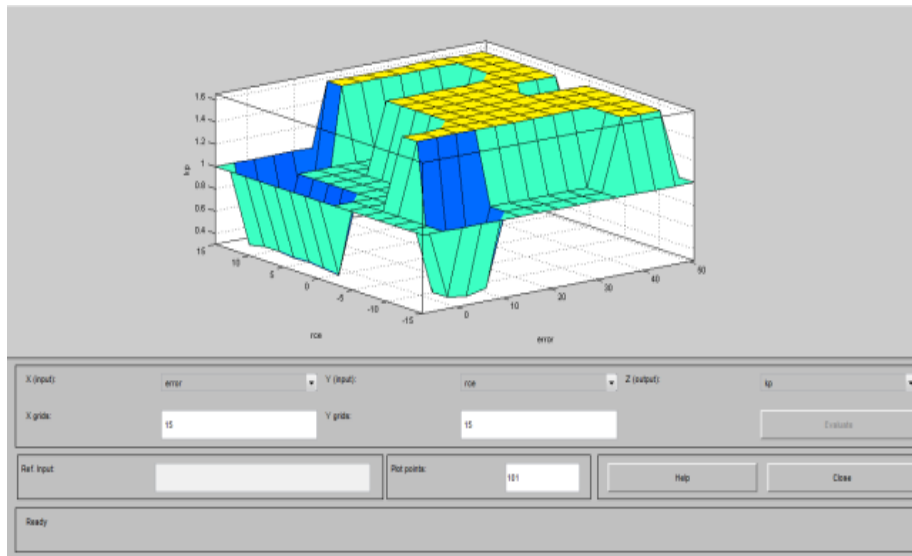

Figure-9:Rule Viewer

Furthermore, the FLC can be easily programmed into numerous as of now accessible industrial process controllers. By using the PID controller, the rise time is less yet oscillations produced, settling time and overshoot is more. Be that as it may, in the event of fuzzy logic controller, settling time, oscillations and overshoot time are low. Therefore fuzzy logic controller gives better result.

#### 4. CONCLUSION

In contrast to many other complex, or thousands, of controls that sudden spike in demand for committed PC systems, a special FLC that utilizes few principles and direct execution is proposed to settle a classification of value control issues with obscure force or adaptable time delays found in the industry. Moreover, the FLC can be effortlessly arranged for most existing modern processors. FLC made by quality control issue with promising outcomes can be applied to totally extraordinary industry-level assets. The outcome shows a huge improvement in execution over the more generally utilized PID structure regarding created oscillations and overshoots. The increase time in case of a PID control is little yet the oscillations are delivered and surpassing the settling time is longer. Be that as it may, in case of preposterous rationale control, motions and overshoot and goal time is low, at that point FLC can be utilized where the output is horrendous. FLC additionally shows solid execution of plants with critical contrasts in energy. Here FLC and PID are both utilized in a similar quality control framework and reproduction results are accessible. On the off chance that these methods had been applied to a framework whose particular framework elements were obscure, PID would not have considered obscure force or variable time delays in the framework. Fluffy Logic offers a totally extraordinary, unconventional method of finding a control issue. This methodology centers around what the framework ought to do instead of attempting to see how it functions.

#### 5. REFERENCES

- [ 1] Ansarifar,R.G, Talebi, A.H & Davilu,H. (2012),”Adaptive estimator-based dynamic

- sliding mode control for the water level of nuclear steam generators”, *Progress in Nuclear Energy*, vol.56, pp. 61-70.
- [ 2] Liu,C, Zhao,Y.F, Hu,P, Hou,S&Li,C ‘P(2010)-controller with partial feed forward compensation and decoupling-control for the steam generator water level’, *Nuclear Engg. & Design*, vol. 240, pp. 181-190.
- [ 3] Moradi, H,Avval, S.M and Nejad,B.F, (2012), ‘Sliding mode control of drum water level in an industrial boiler unit with time-varying parameters: A comparison with  $H-\infty$  robust control approach’, *Journal of Process Control*, vol. 22, pp. 1844-1855
- [ 4] Maffezoni, C, (1997), ‘Boiler-Turbine dynamics in power-plant control’, *Control Eng. Practice*, vol. 5, pp. 301-312.
- [ 5] Safarzadeh, O., Kahki Sedigh, A., and Shirani, S.A. (2011), ‘Identification and robust water level regulation of horizontal steam generators using quantitative feedback theory,’ *Energy conversion and Management*, vol. 52, pp. 3103–3111.
- [ 6] Tan,A(2011) ‘Water level control for a nuclear steam generator’, *Nuclear Engineering and Design*, vol.241, pp.1873-1880.
- [ 7] Zhang,Z&Hu,L.S(2012) ‘ Performance assessment for the water level control system in steam generator of the nuclear power plant’, *Annals of Nuclear Energy*, vol.45, pp. 94-105. 30
- [ 8] Zhang,D, Yang,H.X, & Chen, W(2012), “Research on pressurized water level control of PWR nuclear power station’, *Energy Procedia*, vol. 16, pp. 849- 855.
- [ 9] Aravindaguru I, Ramkumar R, Sanjoy Deb, (2019), “An Automated Sensor System for Livestock Detection, Identification and Warning System based on the Ground Vibration in Cultivation Fields” in *Bioscience Biotechnology Research Communications*, Vol. 12 Issue No. 3, MAY 2019.
- [ 10] Kiruthika, S., Starbino, A.V., “Design and analysis of FIR filters using low power multiplier and full adder cells,” *Proceedings - 2017 IEEE International Conference on Electrical, Instrumentation and Communication Engineering, ICEICE 2017*, 2017, 2017-December, pp. 1–5
- [ 11] S Kiruthika, P Sakthi, K Raam, G Sanjay, M Mohamed Rafi, “Vision Based Smart Parking System”, *Turkish Journal Of Physiotherapy And Rehabilitation*, N; 32(2) Issn 2651-4451 | E-Issn 2651-446x, 2021.
- [ 12] S Kiruthika, “Monitoring Soil Quality and Fertigation System Using Iot”, *Turkish Journal of Computer and Mathematics Education*, Vol. 12 No. 9 (2021)
- [ 13] K. Yasoda, R. Ponmagal, K. Bhuvaneshwari, and K. Venkatachalam, "Automatic detection and classification of EEG artifacts using fuzzy kernel SVM and wavelet ICA (WICA)," *Soft Computing*, vol. 24, no. 21, pp. 16011-16019, 2020.
- [ 14] C. Viji, N. Rajkumar, S. Suganthi, K. Venkatachalam, and S. Pandiyan, "An improved approach for automatic spine canal segmentation using probabilistic boosting tree (PBT) with fuzzy support vector machine," *Journal of Ambient Intelligence and Humanized Computing*, pp. 1-10, 2020.
- [ 15] K. Venkatachalam, A. Devipriya, J. Maniraj, M. Sivaram, A. Ambikapathy, and S. A. Iraj, "A novel method of motor imagery classification using eeg signal," *Artificial intelligence in medicine*, vol. 103, p. 101787, 2020.
- [ 16] S. K. Vasudevan, K. Venkatachalam, H. Shree, R. B. Keerthana, and G. Priyadarshini, "An intelligent and interactive AR-based location identifier for indoor navigation," *International Journal of Advanced Intelligence Paradigms*, vol. 15, no. 1, pp. 32-50, 2020.
- [ 17] S. Subramanian, R. Regan, T. Perumal, and K. Venkatachalam, "Semi-Supervised



- Machine Learning Algorithm for Predicting Diabetes Using Big Data Analytics," in *Business Intelligence for Enterprise Internet of Things*: Springer, 2020, pp. 139-149.
- [ 18] Punithavathani, D. Shalini, K. Sujatha, and J. Mark Jain. "Surveillance of anomaly and misuse in critical networks to counter insider threats using computational intelligence." *Cluster Computing* 18.1 (2015): 435-451.
- [ 19] Sujatha, K., and D. Shalini Punithavathani. "Optimized ensemble decision-based multi-focus imagefusion using binary genetic Grey-Wolf optimizer in camera sensor networks." *Multimedia Tools and Applications* 77.2 (2018): 1735-1759.
- [ 20] Chang, Jinping, Seifedine Nimer Kadry, and Sujatha Krishnamoorthy. "Review and synthesis of Big Data analytics and computing for smart sustainable cities." *IET Intelligent Transport Systems* (2020).
- [ 21] Song, Hesheng, and Carlos Enrique Montenegro-Marin. "Secure prediction and assessment of sports injuries using deep learning based convolutional neural network." *Journal of Ambient Intelligence and Humanized Computing* 12.3 (2021): 3399-3410.