

Experimental Analysis on Lpg-Jatropha Dual Fuel Engine

Radhakrishnan, S¹, Bharathi R², A. C. Ramkumar³, M. Maheshkumar⁴

^{1,2,3,4} Department of Mechanical Engineering, Nehru Institute of Technology, Kaliyapuram, Coimbatore 6411 05, Tamilnadu, India

Email: nitsrk75@gmail.com

Abstract: *Because of increased emissions in diesel engines, dual fuel engines are more attractive over diesel engines. Gaseous fuels can be effectively used in diesel engines modified to work in dual fuel mode. Diesel blended with methyl ester of jatropha oil in the ratio of 80:20 (volume basis) is utilized as a pilot fuel, and LPG is inducted along with the fresh air at a constant flow rate of 175 g/hr through the intake manifold of the CI engine. LPG – Biodiesel dual fuel engines emit marginally higher NO_x emissions at full load, as compared to that of diesel engines, as higher cylinder temperatures achieved during combustion.*

Keywords: *Jatropha, Bio-fuels, Vegetable oils, Blending, Preheating, Transesterification, Emission*

1. INTRODUCTION

The world, at present is heavily dependent on petroleum fuels. Due to the fast depletion of petroleum reserves, the importance of alternate fuel research for internal combustion engines needs no emphasis. Diesel engines are the main prime movers for public transportation vehicles, stationary power generation units and for agricultural applications. In developing countries much of the population is in rural areas and small diesel engines are used in a highly decentralized manner for pumping, electricity generation and operating other agricultural machinery. These engines can be powered by vegetable oils, which are readily available in rural areas. The level of emissions that can be tolerated is much higher in rural areas as the population density of engines is not very much. Vegetable oils can be directly used in diesel engines with out any modifications [1-3]. Many of their properties are close to diesel and they are miscible with diesel in all proportions. Vegetable oils have also been converted to their ethyl or methyl esters (Biodiesel) and used in diesel engines. Biodiesels are much better fuels than raw vegetable oils. Their properties are very close to diesel.

The high viscosity and low volatility of vegetable oils leads to poor mixture formation. This results in slightly lower thermal efficiency than that of the diesel engine and also high smoke levels. These problems of vegetable oils can be overcome by properly modifying the fuel. The methods employed include blending, heating, thermal cracking and transesterification of vegetable oils to convert them to biodiesel. Many investigators reported better performance and lower emissions by adopting the above methods [4,5]. Senthilkumar et al. [6] investigated the performance and combustion characteristics of Jatropha oil and its methyl ester in a single cylinder naturally aspirated direct injection diesel engine and compared the

results with conventional diesel fuel. They reported that the overall performance, emissions and combustion characteristics of the methyl ester of jatropha oil are comparable to diesel.

Gaseous fuels are clean burning. Hence, they have attracted worldwide attention. Many of the gaseous fuels can be obtained from renewable sources. They have a high self-ignition temperature and hence are excellent spark ignition (SI) engine fuels. However, they cannot be used directly in diesel engines. But diesel engines can be made to use a considerable amount of gaseous fuels in the dual fuel mode. In the dual fuel engine a gaseous fuel called the primary fuel is either inducted along with intake air or injected directly in to the cylinder and is compressed like in a conventional diesel engine. The mixture is then ignited by a small amount of diesel, called the pilot fuel and combustion of the gaseous fuel starts. The major advantages of the dual fuel engines are their ability to use a wide range of gaseous fuels and also to produce smoke levels lower than that of conventional diesel engines. Karim [7] has done extensive work on dual fuel engines with different fuels.

LPG has many advantages as a fuel for internal combustion engines. It is comparatively cheap, easy to store, distribute and available in many parts of the world. It has high energy density and a high-octane value. Hence, it is suitable for high compression ratio engines. It mixes uniformly with air and results in good combustion with reduced emissions. Poonia [8,9] has reported extensively on the performance of a dual fuel engine with LPG as the primary fuel and diesel as the pilot fuel and the influence of different variables. He reported that the performance is better than diesel a high loads but at lower loads the brake thermal efficiency is always lower than that of diesel values.

In the present work an attempt has been made to investigate the effect of substituting the biodiesel of Jatropha oil for conventional diesel engine as pilot fuels in a LPG inducted dual fuel engine. Jatropha oil is available in rural areas and the distribution network for LPG is fairly well established in India even in the rural areas.

2. EXPERIMENTAL SETUP AND EXPERIMENTS

A single cylinder, four stroke, direct injection, water cooled diesel engine is used for the experiments. The engine is modified to work in the dual-fuel mode by attaching LPG line to the intake manifold. A schematic layout of the test set-up is shown in figure 2.1 and engine specification is given in table 1.

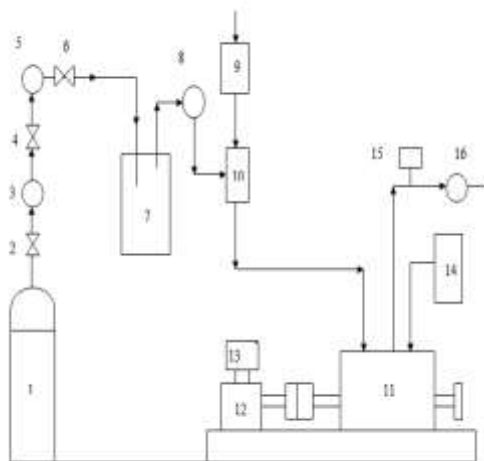

Fig 2.1 Schematic diagram of experimental set up

1. LPG Cylinder
2. Pressure regulator
3. Pressure gauge
4. Flow controller
5. Flow meter.
6. Non-return valve
7. Flame trap
8. Control valve
9. Air surge tank
10. Gas mixture
11. Engine
12. Electrical dynamometer
13. Loading device
14. Fuel tank
15. Exhaust gas analyser
16. Exhaust outlet

All the tests conducted at a constant speed of 1500 rpm at various loads ranging from no load to full load at constant intake air temperatures and with various pilot fuel quantities. Optimum static injection timing of 24° BTDC and optimum injector opening pressure of 200 bar both in the diesel mode and in the dual fuel mode is set for the experiments. LPG is inducted at a constant flow rate of 175 g/hr through the intake manifold of the CI engine. Diesel blended with the jatropha oil in the ratio of 80:20 (by volume basis) is injected as a pilot fuel at the end of compression stroke.

Table 1. ENGINE SPECIFICATION

Make	Kirloskar TAF-I
No. of cylinders	One
Type of cooling	Air cooling
Ignition	Compression ignition
Bore	87.5mm
Stroke	110mm
Compression ratio	17.5:1
Rated speed	1500rpm
Brake power	4.4kW

3. TRANSESTERIFICATION PROCESS

For transesterification process, 1 lit of jatropha oil is taken in a round bottom flask; 10 ml of H₂SO₄ is dissolved in 333 ml of methanol in a separate vessel, which is poured into round bottom flask while stirring the mixture continuously using constant stirring mechanism. The mixture is stirred and maintained at 70°C for 1 hour and then allowed to settle down under gravity in a separating funnel. Ester formed the upper layer in the separating funnel and glycerol formed the lower layer. Then glycerol is separated from a mixture. The separated ester is mixed twice with the water and allowed to settle under gravity for 24 hours. The catalyst got dissolved in water, which forms lower layer, and is separated. Moisture is removed from this ester using silica gel crystals. To remove the acid impurities, some amount of base (NaOH) is added. The time required for biodiesel production is about 48 hours. The photographic view of transesterification setup is shown in figure 3.1.



Fig3.1 Photographic view of transesterification set up

4. RESULTS AND DISCUSSION

4.1 Brake Specific Fuel Consumption

Figure 4.1 shows the comparison of brake specific fuel consumption of diesel and LPG-Biodiesel dual fuelled engine.

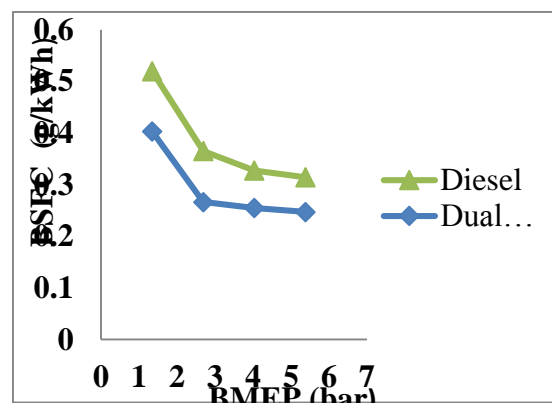

Fig 4.1 Variation of BSFC with BMEP

From the graph, it is observed that brake specific fuel consumption of the engine in dual fuel mode is decreased by 21.34% compared to that of neat diesel fuel. This is due to the operation of LPG fuelled engine at leaner equivalence ratio.

4.2 Brake Thermal Efficiency

The variation in the brake thermal efficiency of LPG-Biodiesel dual fuelled engine is shown in figure 4.2.

From the graph, it is observed that brake thermal efficiency of dual fuel engine at light load is slightly lower (1.22%) than that of diesel fuel. This is due to the lesser quantity of pilot fuel.

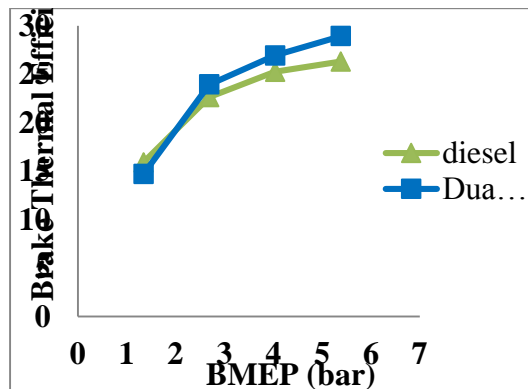

Figure 4.2. Variation of Brake thermal efficiency with BMEP

As the pilot fuel quantity increased when load increases, brake thermal efficiency is improved by 3% compared to that of neat diesel fuel. This is due to the better combustion of the fuel.

4.3 Unburned Hydrocarbon emission

Figure 4.3 shows the variation of HC emissions of LPG-Dual fuelled engine.

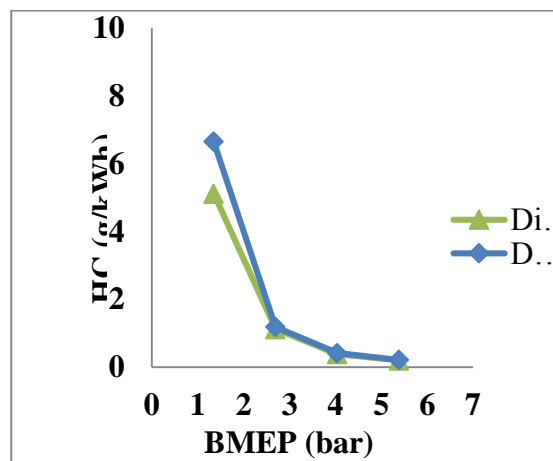

Figure 4.3 Variation of HC with BMEP

Increase in hydrocarbon (HC) emissions is observed when the engine was running at dual fuel mode. HC emission for dual fuel engine is increased by 23.09% at 25% load than that of neat diesel fuel. This is due to insufficient amount of oxygen that enters into the combustion chamber of the engine and hence incomplete combustion of fuel. As the pilot fuel quantity increased at higher loads, it enhanced combustion and minimum difference in HC emission is observed for both the fuel modes (diesel & dual fuel).

4.4 Carbon monoxide emission

Figure 4.4 shows that carbon monoxide is increased when the engine was running in dual fuel mode.

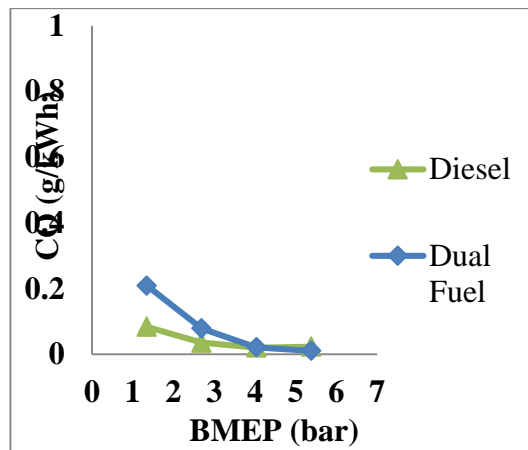

Figure 4.4 Variation of CO with BMEP

Higher CO level formation at no load can be attributed to increased percentage of pilot fuel substitution, which perhaps resulted in partial oxidation of inducted LPG during compression and combustion.

4.5 Carbon dioxide emission

The variation in carbon dioxide emission of LPG-Biodiesel dual fuel engine is shown in figure 4.5

Incapability of carbon monoxide to convert into carbon dioxide caused the increase in CO level and decrease in CO₂ emissions level

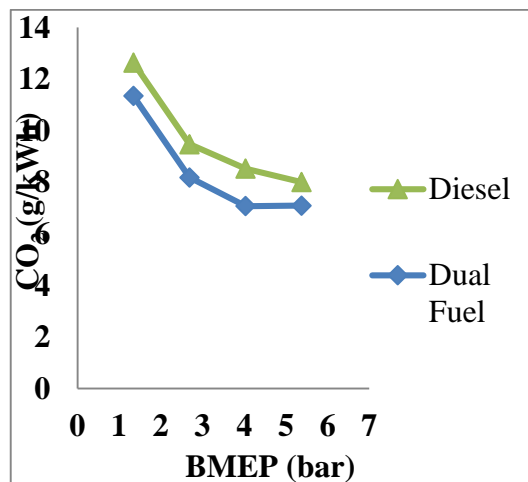

Figure 4.5 Variation of CO₂ with BMEP

4.6 Oxides of nitrogen emission

The variation in oxides of nitrogen of LPG-Biodiesel dual fuelled engine is shown in figure 4.6.

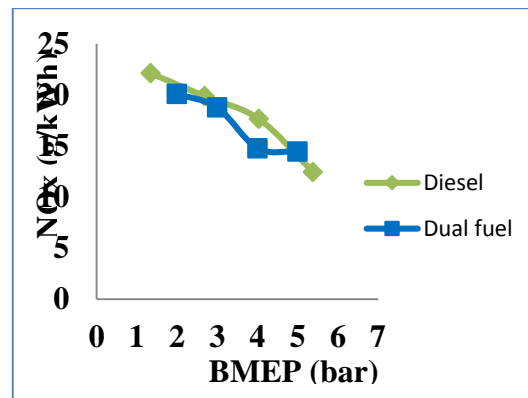

Figure 4.6 Variation of NO_x with BMEP

The NO_x formation in dual fuel mode at full load is increased by 7% compared to that of neat diesel fuel. This is because at higher loads, increased quantity of pilot fuel and better combustion of inducted LPG resulted in higher temperatures, which possibly increased the NO_x emissions. With the introduction of EGR, the NO_x emission can be reduced.

5. CONCLUSION

The following conclusions are drawn from the experimental investigations carried out:

1. Brake specific fuel consumption of the engine without EGR is decreased by 21% compared to that of neat diesel fuel. With the introduction of 10% and 20% EGR, the BSFC is further reduced.
2. A marginal improvement in brake thermal efficiency is found in dual fuel mode at full load.
3. HC emission is increased by 23% at part load in dual fuel mode as compared to that of neat diesel fuel.
4. Like HC emissions, CO emission is also increased in dual mode as compared to that of neat diesel fuel due to the incomplete combustion of fuel.
5. Carbon dioxide emission is decreased in all the conditions as compared to that of neat diesel fuel operation.
6. The NO_x formation of dual fuel engine at full load is higher around 7% compared to that of neat diesel fuel due to peak combustion temperature.

6. REFERENCES

- [1] Jacobus.M.J, Geyer. S.M, Lestz.S.S, Taylor.W.D and Risby.T.H, "Single- Cylinder Diesel Engine Study of Four Vegetable Oils", SAE paper No. 831743 (1983).
- [2] Nazar.J, amesh.A and Sharma. R.P, "Performance and emission studies on use of SVO and Biodiesel from different Indian Feedstock", Paper no. 145, 4th International symposium on fuels and lubricants, New Delhi, India (2004).
- [3] Nazar. J, Sandesh. G, Ramesh. A and Nagalingam. B, "Use of vegetable oils in diesel engines", Proceedings of National Conference on State of the art of Technologies in Mechanical Engineering (NCSAME-2004), pp 422-429 (2004).
- [4] Nazar. J, Ramesh.A, Ramesh. A and Nagalingam. B, "Performance and emission characteristics of a diesel engine using preheated vegetable oils", National conference

- on alternate fuels for automobiles, Institute of Road Transport Technology, Erode, pp 11-16 (2004).
- [5] Raheman.H, Phadatare. A.G. Diesel engine emissions and performance from blends of karanja methyl ester and diesel”, Biomass and Bioenergy 27 393-397 (2004).
 - [6] Senthil kumar.M, Ramesh. A and Nagalingam. B, “Investigations on the use of Jatropha oil and its methyl ester as a fuel in a compression ignition engine”, International journal of the institute of energy, UK, 174, pp 24-28 (2001).
 - [7] Karim. G.A, “The dual fuel engine of the compression ignition type-prospects, problems and solutions- a review”, SAE paper No.831073 (1983).
 - [8] Poonia. M.P, Ramesh. A, Gaur. R.R, ‘Experimental investigation of the factors affecting the performance of a LPG-diesel dual fuel engine”, SAE paper No. 1999-01-1123 (1999).
 - [9] Poonia.M.P, Ramesh. A, Gaur. R.R, “Effect of intake and pilot fuel quantity on combustion characteristics of a LPG-diesel dual fuel engine”,SAE paper No.982455 (1998).