

Permanent Magnet Synchronous Generator Based Wind Energy Conversion System With Power Management System Using V/F Technique

Dr. Firos A¹, Dr. Joshi. Vinayak. Bhalachandra², Dr. Sidagouda Patil³, Emmanuel Babu Pukkunnen⁴, Lakshmi Devadas⁵, Sabarimuthu.M⁶

¹Assistant Professor, Department of computer Science and Engineering, Rajiv Gandhi University (A central university), Rono-Hills, Doimukh, Arunachal Pradesh, India.

²Department of computer Science and Engineering, Belgaum, Karnataka, India

³Principal, VSM's BBA BCA and Degree College, Nipani, Karnataka, India.

⁴Assistant Professor, Dept. of EEE, Mar Athanasius College of Engineering, Kerala, India.

⁵Power System Design Engineer, ETAP Automation Pvt Ltd, Navi Mumbai, Maharashtra, India.

⁶Assistant Professor (Sr. G), Department of EEE, Kongu Engineering College, Perundurai, Tamilnadu, India.

Email: ¹Firos.a@rgu.ac.in

Abstract: As fossil supplies deplete, worldwide demand for more inexpensive and accommodating energy production habitats has increased throughout the decade of the 2000s. In relation to task labor, renewable resources are a key aspect of destiny technology during the last few years. In comparison to other sources, wind energy is one of the recommended options for businesses looking for renewable energy. To harvest as much energy as possible, management approaches must be devised which use the unpredictable and irregular character of wind. thus, in this thesis, criteria for a Hill-climb search (HCS) have been implemented, which when used with the turbine, is able to find the optimum position on the power tower and furthermore shows battery functioning with no bias towards one energy conversion method (WECS). In layman's terms, the hill climb seek algorithm is asymmetric to the wind farm power speed. characteristics and wind speed, and therefore it has the ability to climb steeper grades with less wind speed. One of the results of this is that the speed of the generator rotates in step with the load, with the synchronization coming from either the hybrid energy storage system (PMSG). Variability of load operation and versions of fault and overloads results in significant frequency and voltage fluctuations within the grid. A voltage regulator (VSC) plus hybrids battery storage medium is used to implement a voltage-frequency (VF) controller. Which will prove the correct functioning of the VF controllers is monitored regularly in a MATLAB-based SIMULINK environment in which frequent voltage and frequency variations are introduced to the WECS.

1. INTRODUCTION

Due to the obvious increasing public concern about the traditional power-hungry techniques, they are being replaced with more environmentally friendly, renewable energy options. It is

predicted that there is a finite amount of non-renewable energy outside the globe, and it will be used up within thirty to fifty years. In other words, we must turn our attention to another option which will help focus attention on limitless resources. This region has a strong flow of wind vitality, and there are no limitations on it. In addition, the circumstances are excellent for the production of more wind vitality. Even yet, because the system relies on wind, it has to be equipped with a meticulous control system to pick up as much control as feasible.

This return to the year 1970 with the advancement of the present WECS shows how lengthy the progress took. In addition to the previously mentioned breakthroughs, current-day control electronic devices, such as turbines with simplified features, and flagpole settings, have allowed power plants to produce more energy with lower costs. Investigations in the area of the most extreme power created from wind-energy transformation frameworks have helped to shift the wind industry's view on renewable power from being one of preference to one of need.

The wind has been utilised for thousands of years for many purposes including transporting goods, grinding cereals, and desalinizing rainwater sources. This kind of electricity production has never been used till recently. This occurred in the latter half of the 1990s, when the technology was advanced enough to implement large-scale production. The top 5 global wind market players as shown in Figure 1 include China (115 MW), the United States (66 MW), German (39 MW), Indian (22.5 MW) & Portugal (22 MW). Figure 2 shows that overall breeze vitality business has grown steadily at a rate of 30% over the last decade but had a short setback in 2013.

Wind's current market value is now at \$369,597 million, equal to \$370 billion. Additionally, we will need to increase our pace to 40% over the next several years. WECS has managed to become better both in terms of cost and output due to the latest development and research in the area of electrical gadgets and electrical machine.

Wind vigour isn't just benevolent but furthermore it improves local economies and aids countries in preserving their independence by warding off stuns to their macroeconomics produced by increases in the price of world goods like oil, gas, and coal. Various administrations have supported and appreciated the breeze vitality programmers throughout the globe. In the decade of the 1990s, in India, the wind energy endeavor got under way, and in the following couple of years, it rapidly developed.

At the moment, India is the sixth most spectacular generator of wind power. The majority of Breeze Vitality's locations are located on the southern coast of India. Currently, Suzlon, an Indian-based company, has approximately 43% of the wind power market in India. As a result, India is a pioneering pioneer in today's wind innovation.

The largest breeze control facility in India is a significant increase in the number of wind turbines (1500 MW) in Tamil Nadu. Moreover, India has wind control plants with age limits above 10 MW, and there are over 24 of them. Even so, since 2015, only 8.5% of our countries' combined control age has been implemented. With respect to the expansion of life in India, the main obstacle is the significant installation expense, along with wind circumstances that are unpredictable in India. Installation and some other creation costs

consume a staggering amount of money and, as a result, the expense of wind-produced control has drastically increased, which puts the burden on the government to underwrite costs in order to improve the reputation of wind turbines.

Overall cumulative gust circulation outpatient rehabilitation ability will increase by 2X by 2022, according to the estimate of MNRE. It shows the increasing ubiquity of wind turbines and how widely they are likely to be used in the coming years. In order to maximise productivity and get the maximum amount of power extraction, you should extract as much power as you can at any speed of the wind.

This is because wind speed is regularly accessible, which encourages flighty ideas. Of course, there is only one optimum power location for every speed. The turbines, which usually don't function at optimum wind speed, must rely on generator stacking in order to maintain performance. As a result, the performance of the turbines continually varies due to changes in load and wind speed. This intensity transformation method fails because it causes wind vitality to be wasted. Also known as MPPT, this technology seeks to follow the optimum power-speed curve at different wind speeds.

For maximum power, the rotational speed of the turbine must be adjusted to the optimum TSR level. Generators with a fixed speed are intended for specific speeds. There must be an appropriate guide that compares to a specific speed for this type of job. Therefore, it is unrealistic to anticipate that one will be able to do the MPPT work on the speed task.

In element speed task extraction, which is where a turbine's many speeds come into play, it is possible at all speeds. While in the WECS, variable-speed activities are often preferred. No recurrence management is required in established speed activities when the generator and the framework have the same recurrence. That is not to say, however, that if the need for speed control did emerge, the situation would be inescapable. Because of the variability in the workload, the matrix frequency of the breezy generator is unique, and each change in load or wind strength must be done individually.

The foundation voltage level recurrence may be affected by the vehicle's speed. A weaker network is more likely to have flaws and power outages. We should build a controller that varies the voltage and how often it occurs. This will serve to reinforce a steadfast and resolute force in time.

The motivation for this business is to establish an autonomous WECS system in remote areas, distant from electric infrastructure. Individuals in these areas have to rely on renewable energy resources since all their energy comes from one or two sites. Whenever there is an ample amount of wind for a significant part of the year, wind energy is a preferred choice. Wind vitality offers a nation a great number of advantages. For example, it has no conditions, it might be a great spring for the local economy, and it produces appealing cash. All of these wonderful advantages are combined with the wind-vitality benefit.

To be sure, no matter how erratic the wind may be, a control system should be implemented to better regulate generation at different wind speeds. Because of the advancement of load circumstances, the matrix voltage varies with the pace of the load. Breakdowns and decreased

existence of gadgets happen to the overwhelming majority of family devices, which all have a defined functioning voltage and recurrence, as well as a constant modification in these characteristics. A voltage-recurrence controller is required to prevent excessive changes in voltage.

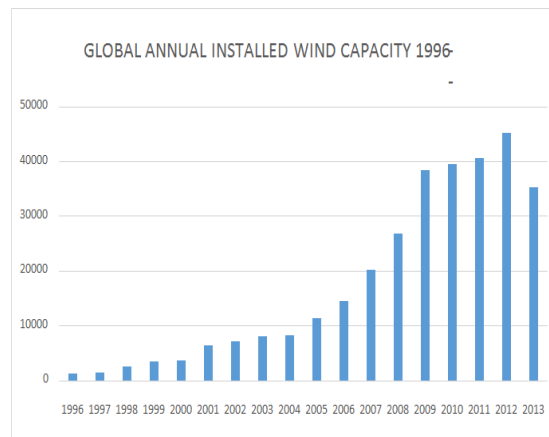

Figure 1. Diagram of Within the year 1996, the global yearly average wind velocity capabilities in watts were attained.

2. WECS-PMSM

In this WECS design, a breeze turbine is connected to a PMSG, and the control of the turbine is modified with the help of a diode connect rectifier. Afterwards, the rectified power is maintained until it reaches the voltage level of the DC-connector. The MPPT controller is in charge of controlling the exchange of the Boost converter. A battery is connected to the DC-connection in order to provide or store electricity.

A shortage in electricity or the need for more power The IGBT inverter converts the direct current control to alternating current control. The three-stage stack is connected to the inverter through a cable. It is possible to create a generic Wind Renwick framework that contains three components: the wind turbine, the wind generator, and the rigging boxes game plan. As a result, the many types of turbines and generators that are now available are discussed here. When it comes to wind energy transition systems, the power plant is the primary and most important component. Wind farms (WT) are divided into two groups based on the location of the hub for the insertion of sharp edges on the turbine blades.

- WT horizontal pivot WT horizontal pivot WT
- Vertical pivot WT (vertical pivot)

The leveling pivot turbine is named for the fact that its cutting edges are aligned with the even hub. The overall growth of a HAWT comprises an apex with a level clean edge at the best, which is referred to as a nacelle in French. The nacelle is responsible for mounting the generator and gearbox. In this way, HAWT are mechanically more unpredictable; the centrifugal activity of the turbine sharp edge generates pressure when the yaw portion swings to catch the wind, for example. Extra minutes of this pressure may cause the cutting edge of the turbine to break, and the entire structure will be pulverized. It has a greater setup expense since it need more seasoned assistance and maintenance. However, due of its greater change efficacy and self-starting activity, it is well-known in wind untreated control for its role in

reducing wind speed. In a HAWT, the turbine chopping edges are always exposed to the wind, which results in greater lift drive.

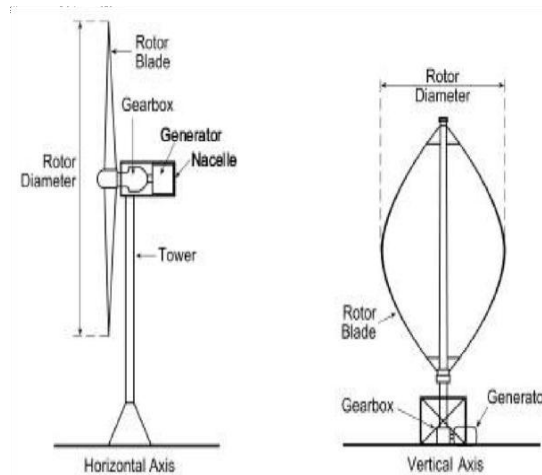

Figure 2. HAWT & VAWT

Additionally, the higher height layout of a HAWT provides it the capability of self-starting, which is advantageous. Consequently, it is better suited for use in high-breeze regions and wide-open areas where large amounts of energy are required for large-scale energy generation. Figure shows a standard HAWT with no special features.

This kind of architecture, on the other hand, raises the cost of power electronic circuits significantly. As implied by the name, FSWECS makes use of a game plan with a fixed rotor speed. In Denmark, this kind of arrangement is very well-known and widely used. As a result, they are referred to as "Danish WECS." A popular method of recruiting for FSWECS is to use recruitment generators, which is advantageous because to the close coupling that exists between the stator and also the matrix. When compared to VSWECS, FSWECS are mechanically energetic, smart, low-maintenance, and rock-solid in construction.

When operating under a stable load and rotor speed, FSWECS performs well and does not need any voltage recurrence setting adjustments. No matter how you look at it, every change in load or wind speed causes the power network to wobble, which is why an unchangeable matrix must be designed for this architecture. The optimal power extraction cannot be achieved in this environment because the rotor speed must be maintained constant.

Its adaptive operation of a framework of this kind has made significant progress. Based on the stage current qualities, the d-q pivot present abilities are determined by applying Clark and Park change hypotheses to the present qualities.

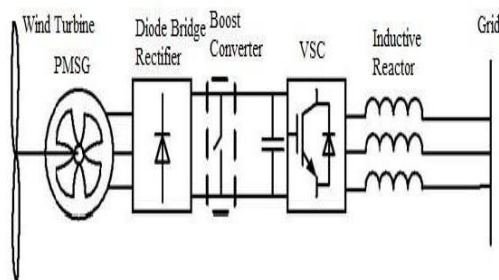

Figure 3. PMSG based WECS.

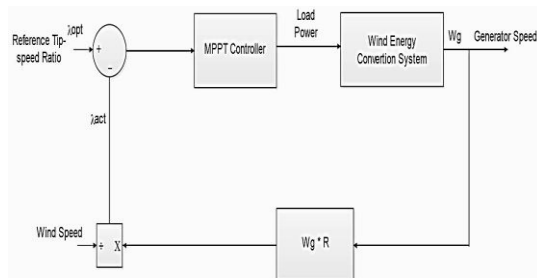
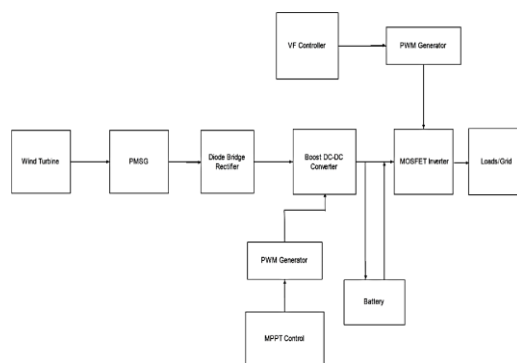

Figure 4. TSR with MPPT

An integrated three-way single technique is used to regulate the generator torque, speed, and transition linkage by the system used in this control process. The error in speed is urged to a PI controller, which provides the generator torque, and the error in torque is encouraged to another PPI controller, whose output provides actual stages point disparity between PMSG motion and actual stator transition, respectively. The determination of the PWM flag is made based on these estimates and the opposing Park's change.

It is possible to use three phase field hypotheses (SRF) in conjunction with PID controllers to evaluate the reference stack current, and PI controllers may be adjusted to refute unflinching state blunder. With the help of Park's change hypothesis, the heap current is transformed from an a-b-c edge to a d-q-0 outline and back. High-pass channels are used to extract symphonious portions from the d-q pivot current, which is composed of centre local. The framework recurrence is obtained via the stage bolted circle in order to measure the present portion of the d-hub (PLL).



and output power seem to increase following the change in the activity of the VF controller shown in Fig.6 and Fig.7.

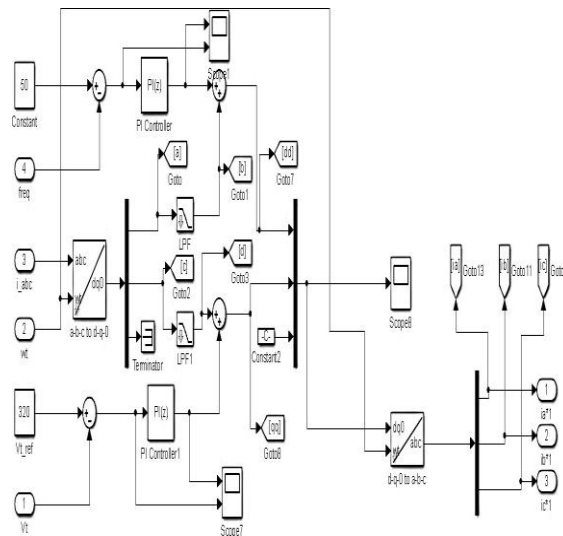

Figure 7. Model of a Voltage Frequency Controller created in Simulink.

When supplying power to the motors at lower twist speeds, the battery provides more power than necessary to achieve speed. As shown in Figure 5.15, the yield for VF controllers to overload reveals limited variation in recurrence—the benchmark from which the reference is derived, in this case, 50 Hz. According to Exhibit the DC interface's terminal voltage has been settled at its reference value of 320 V, with power increasing. When the battery is first energized to 3 seconds, it provides electricity. Stage A exhibits a constant lattice recurrence, and when the blame is ejected, the voltage and voltage decrease back to their standard conditions.

There are varieties discovered in the charging before that battery has been blamed, even though it is being charged. Once all the blame has been deflected, however, the battery will continue in its own unique charging cycle. Upon the incorporation of the non-direct RL stack to the network, minimal instability in recurrence is observed. After the heap is ejected, the voltage quickly returns to its unique incentive. As the heap is emptied, the battery quickly resumes its charging cycle. The activity of the VF controller is shown fig 8 and 9.

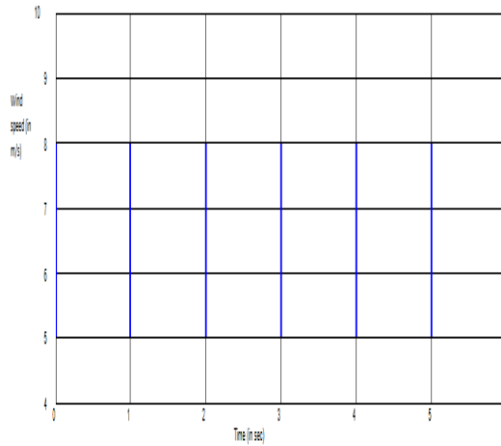

Figure 8. Proposed WECS model in SIMULINK.

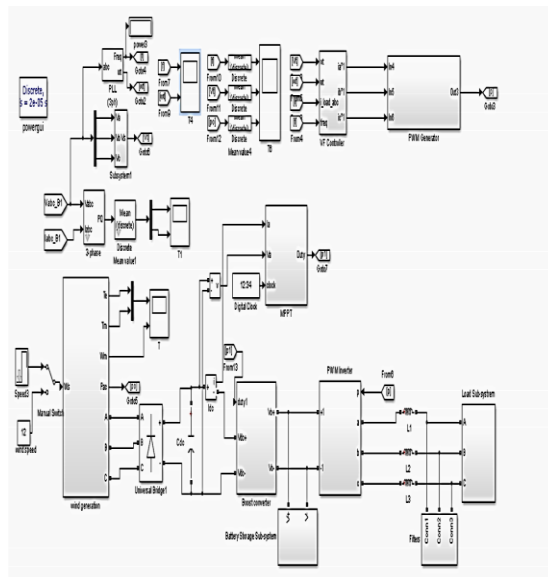

Figure 9. T (ms) Vs Wind Velocity

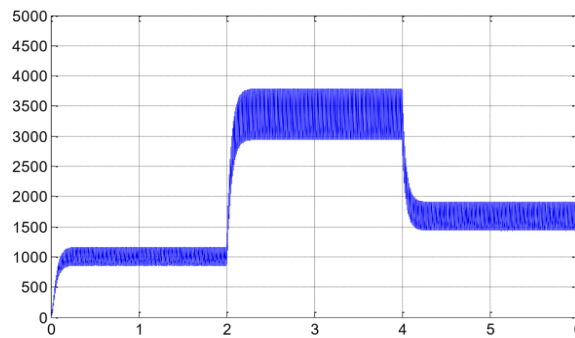

Figure 10. P_o Vs T (Without MPPT)

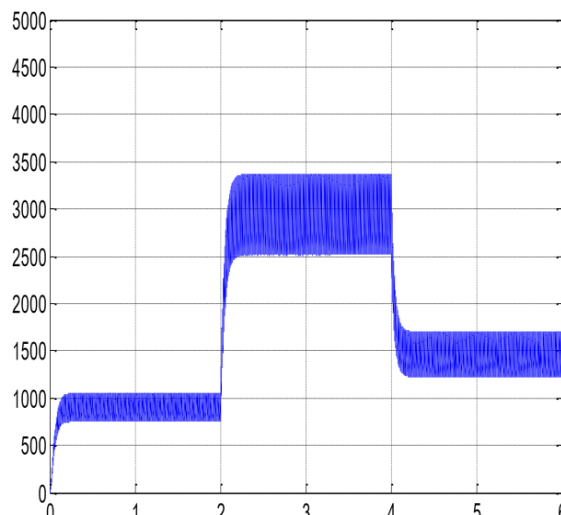
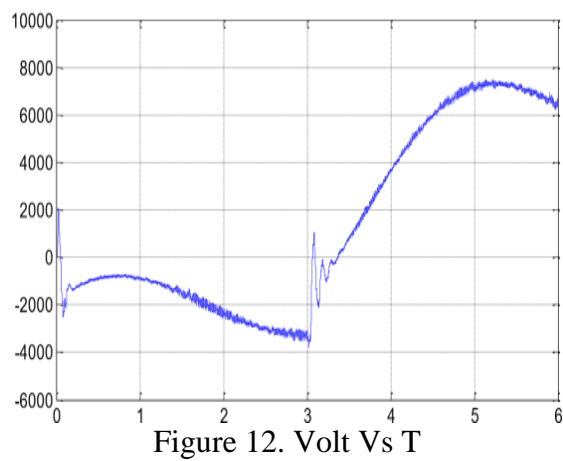
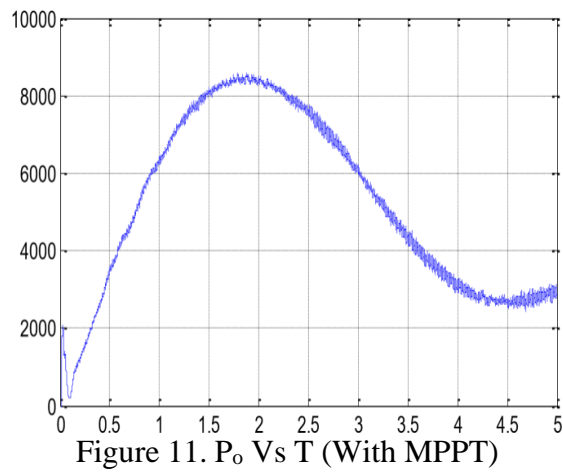

Figure 13. The battery vs time graphic shows that overflow will occur at $t=3$ seconds

4. CONCLUSION

In the event of voltage and AC recurrence, the WECS is based on power electronics and PMSG, which may assist reduce the effects. MPPT calculation was used to simulate the wind

vane control, resulting in better control without Maximum power point tracking. While it is indeed interesting to see effective evacuation because of voltage and current control, there is also a non-direct load that has to be accounted for. Even with failure, the equalization process must continue. Direct current control is being used in this case. DC and AC bar changes. It has also been discovered that when the workload suddenly rises, battery depletion begins to occur, and when the wind picks up, battery charging may occur.

5. REFERENCES

- [1] Haejoon, K. Heesang, K. Hongwoo, K. Hyungoo, K. Seokwoo and all. "Modelling and voltage-control of variable-speed SCIG-based wind farm," *Renewable Energy* 42, June 2012: pp28-35.
- [2] J.L. Domínguez García, O. Gomis Bellmunt, L. Trilla- Romero, A. Junyent-Ferré, "Vector control of squirrel cage induction generator for wind power," *IEEE XIX International Conference on Electrical Machines ICEM'10*, 6-8 Sept. 2010, Rome. pp 1 – 6.
- [3] Kaliappan, S., Parimala, V., Akshay, S., Praneeth, N., Ganthia, B. P., & Upadhyaya, M. (2021). Bridgeless Ac/Dc Converter & Dc-Dc Based Power Factor Correction with Reduced Total Harmonic Distortion. *Design Engineering*, 2012-2018.
- [4] H. Merabet Boulouiha, A. Allali, M. Laouer, A. Tahri, M. Denai, and A. Draou, "Direct torque control of multilevel SVPWM inverter in variable speed SCIG- based wind energy conversion system," *Renewable Energy*, Vol. 80, August 2015, pp: 140–152.
- [5] R. Melicio, V. M. F. Mendes and J. P. S. Catalaño, "Harmonic Assessment of Variable-Speed Wind Turbines Considering a Converter Control Malfunction", *IET Renewable Power Generation*, Vol. 4, No. 2, pp. 139-152, March 2010.
- [6] Athulya M. T, Shankar Subramanian, SVPWM based control of Matrix Converter for gearless operation of wind energy power conversion system, *PESTSE*, 21 July 2016.
- [7] Kaliappan, S., Poornima, M., & Rajeswari, R. (2013, January). Improvement of source voltage and load current harmonic mitigation using UPQC: A survey. In *2013 7th International Conference on Intelligent Systems and Control (ISCO)* (pp. 110-114). IEEE.
- [8] J. Faiz, H. Barati and E. Akpınar, "Harmonic analysis and performance improvement of slip energy recovery induction motor drives," *IEEE Trans. Energy Convers*, vol. 16, no.3, pp. 410-417, 2001.
- [9] S. K. Hyong, L. Dylan Dah-Chuan, "Wind Energy Conversion System from Electrical Perspective – A Survey," *Smart Grid and Renewable Energy*, Vol.1, No.3, November, pp. 119-131. 2010.
- [10] Kaliappan, S., & Thenmozhi, R., "Design and Implementation of PFC CUK Converter-Based PMBLDCM Drive," *Int. Journal of Engineering Research and Applications*, Vol. 4, Issue 2 (Version 1), February 2014, pp.139-143.
- [11] Kaliappan, S., & Rajeswari, R. (2015). A Novel Approach of Position Estimation and Power Factor Corrector Converter Fed BLDC Motor. *International Journal of Power Electronics and Drive Systems*, 5(3), 415.