

Sensor System For Intruder Detection Based On Ground Vibration

Aravindaguru¹, A. Abishek², T. Prasanna³, N. Tamilselvan⁴

^{1,2,3,4} *Department of Electronics and Instrumentation Engineering, M.Kumarasamy College of Engineering, Karur, India.*

Email: ¹aravindagurui.eie@mkce.ac.in

ABSTRACT: *The ground vibration device is used to detect intruders by measuring the vibration of the ground. The movement of an intruder or a human over the ground causes seismic waves to be generated in the soil, which are analyzed by geophones. Personnel monitoring and seismic detection. In light of this, we propose a sensor node that uses a programming language in the current study based livestock detection and identification system based on ground vibration.*

KEYWORDS: *Geophone, Amplifier, Analog Circuit, Data Acquisition*

1. INTRODUCTION

An effective sensor system uses numerous lines of corresponding sensors situated in a detached clear zone, as well as an assortment of inside sensors, to accomplish assurance top to bottom: at the limit, inside the space, and at the protected object. (Snehal boob et.al, Priyanka jadhav et.al, 2010) described about the Topography, foliage, animals, background noise, atmosphere and weather, as well as soil and pavement conditions, are all factors to consider have an effect on the efficiency of external sensors The interaction of the perimeter sensor system with the video appraisal framework and the entrance postpone framework must be considered by the system's designer[1].(Korcak, M., Lamer, J., & Jakab, F., 2014) Vibration sensors come in three types: line, passive, and visible. They are able to sense the movement on the surface, where they are attached. Its construction determines a particular frequency [2]. The impacting method decides the vibration frequencies to a lesser degree. Vibration sensors can range in complexity from simple mercury switches to inertial switches and piezoelectric sensors.

They are intended to react to frequencies related with breaking and entering (normally more prominent than 4 kHz) in each case, as well as to a wide range of other frequencies. Natural building noises, such as noise from air conditioning or heating devices, should be ignored. Vibration sensors have a key application benefit in that they give early warning of a constrained passage. When vibration sensors are introduced on dividers or constructions that are presented to outside vibrations, the planner should know that the detector can create nuisance alarms. Vibration sensors should not be used if the structures are subject to extreme vibrations caused by external causes such as moving machinery. Vibration sensors with a pulse accumulator or count circuit, on the other hand, may be useful if the structures are subjected to only slight impacts.

We'll talk about how to use GSM technology to regulate safety and security systems. In relation to the home protection system, it uses an anti-theft reporting system that will notify the owner via an alarm and an SMS.

2. INTRODUCTION TO GEOPHONE SENSOR

Geophones are used to monitor velocity. They have a magnetic core that is encircled by an electric coil. An electrical current is induced by the movement of the magnet inside the coil, which is tuned to the vibration velocity. If external causes, such as spinning machinery, cause extreme vibrations in the structures, It is not recommended that vibration sensors be used. Vibration sensors with a pulse gatherer or counter circuit, on the other hand, may be useful if the structures are subjected to only slight impacts. Normal frequencies of around 10 Hz and spurious frequencies of around 250 Hz are common. This frequency range precludes the use of geophones for certain purposes, such as pile driving monitoring.

SENSOR SM-24

Geophone with a tight specification and low distortion Over 240 Hz, spurious was expanded, allowing maximum bandwidth at 2-ms sampling. SM-4, SM-4 Superphone TM range, and SM-24ST are backwards compatible. For shear-wave and 3-C recording, a horizontal element is available. Implementation: Compatible with a wide range of I/O Sensor geophone scenarios. A Bluetooth wireless "hat" is connected to the version shown above. The programme for receiving and plotting data, including Arduino code and a Processing-based IDE, is available in the code repositories mentioned below this post. The sensor must be installed on a rig identical to the one shown below for actual seismic measurement. To pick up vibrations, this must then be pushed into the earth. We simply tested the functionality of such a system by putting the sensor on the ground and measuring both the vibrations generated by walking and the vibrations produced on the road by passing vehicles. The fact that we were able to see slight movements in the road before the vehicle went by was particularly intriguing, as it opens up a lot of possibilities.

EXISTING SYSTEM

Domestic automation has been discussed since the last part of the 1970s, (Vini Madan et.al, S.R.N. Reddy et.al, 2012) yet with the advent of technology and facilities, people's perceptions of what a domestic can do and have moved significantly finished time and through the automation system [4]. The figure-1 describes about the existing intruder detection system.

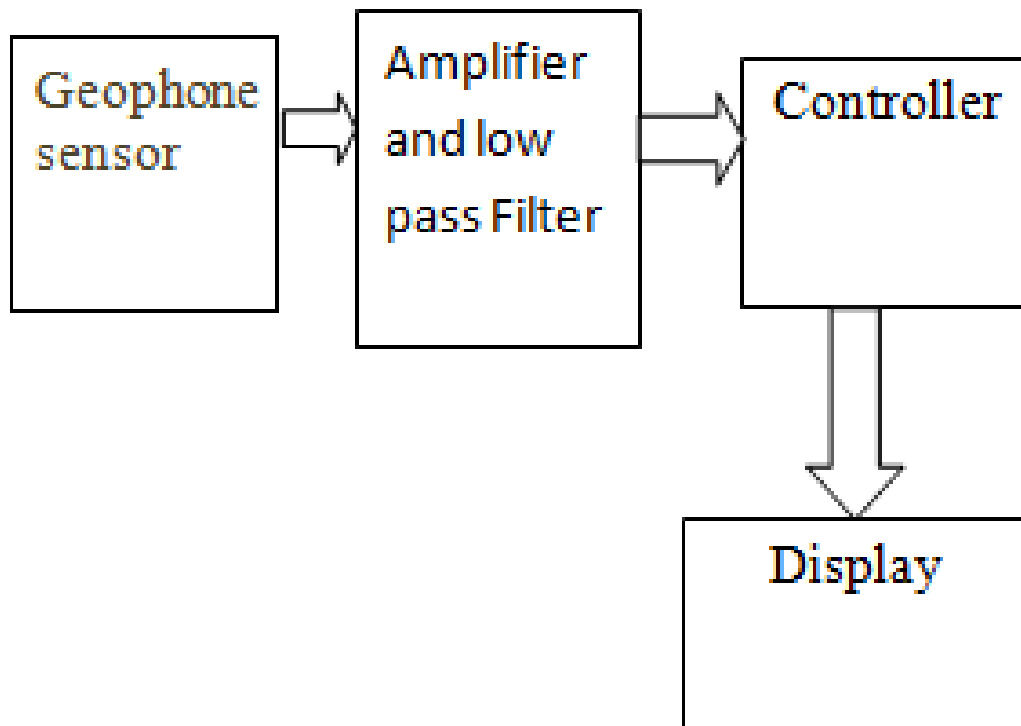

Figure-1: Block diagram of the existing intruder detection system

PROPOSED SYSTEM

This project's proposed framework .They are intended to react to frequencies related with breaking and entering (ordinarily more prominent than 4 kHz)while ignoring typical structure vibrations, for example, cooling or warming hardware commotion in each case. Submissions (Mosad Alkathami et.al, Lubna Alazzawi et.al, and Ali Elkateeb et.al, 2015). The primary benefit of vibration sensors is that they alert you to a forced entry before it happens. When it comes to vibration, If sensors are installed on walls or structures that are subject to external vibrations, the designer must be aware that the detector can generate nuisance alarms [3]. Vibration sensors should not be used if the structures are subject to extreme vibrations caused by external causes such as moving machinery. (P.M. Lange et.al, K.L.G. Nielsen et.al, 2012). If the structures are subjected to sporadic impacts, vibration sensors with a pulse output are recommended accumulator or count circuit might be effective.[5][13][14].

The figure 2 describes about the Block diagram of the proposed intruder detection system and warning system

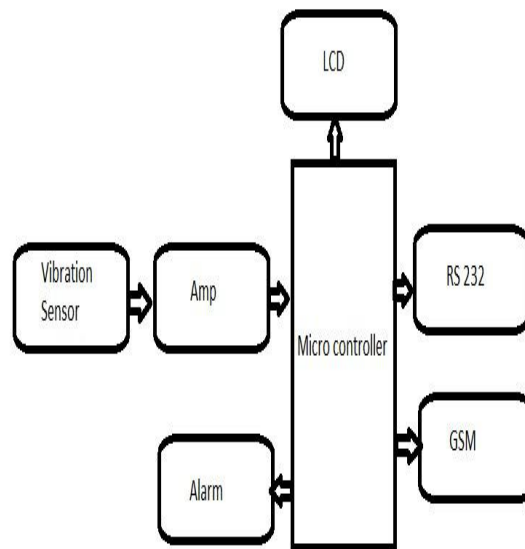

Figure-2: Block diagram of the proposed intruder detection system and warning system

3. RESULTS AND DISCUSSION

This paper describes how an effective sensor system achieves protection-in-depth by utilizing various lines of reciprocal sensors situated in a disengaged clear zone, as well as a variety of interior sensors, to provide a continuous line of detection at the boundary, within the space, and at the protected object.

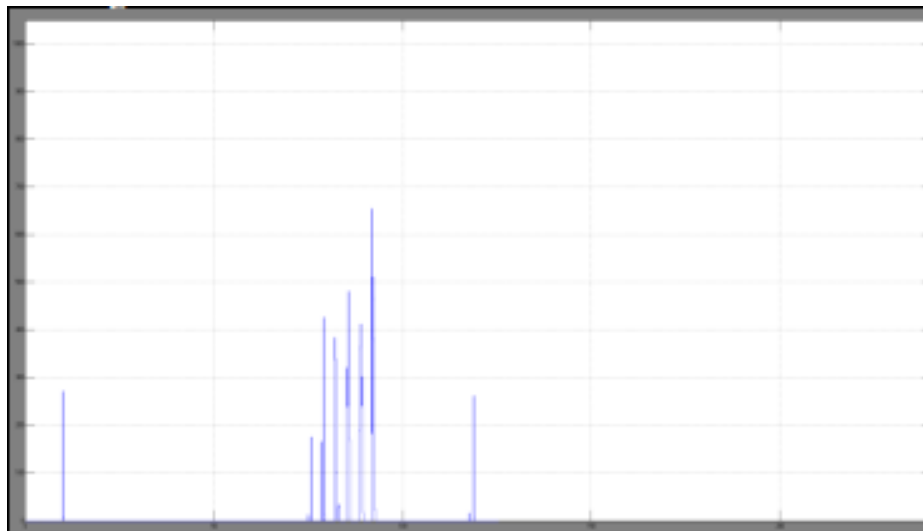

Figure 3: Simulation result for detection of human or intruder crossing over a sensor.

The figure.3 describes about the simulation result of the detection of human or any intruder crossing over the sensor region[15][16][17]. The peak will denote the amplitude of the vibration made over the earth surface[18-21].

The performance of exterior sensors is affected by a number of factors, including weather, soil, and pavement..

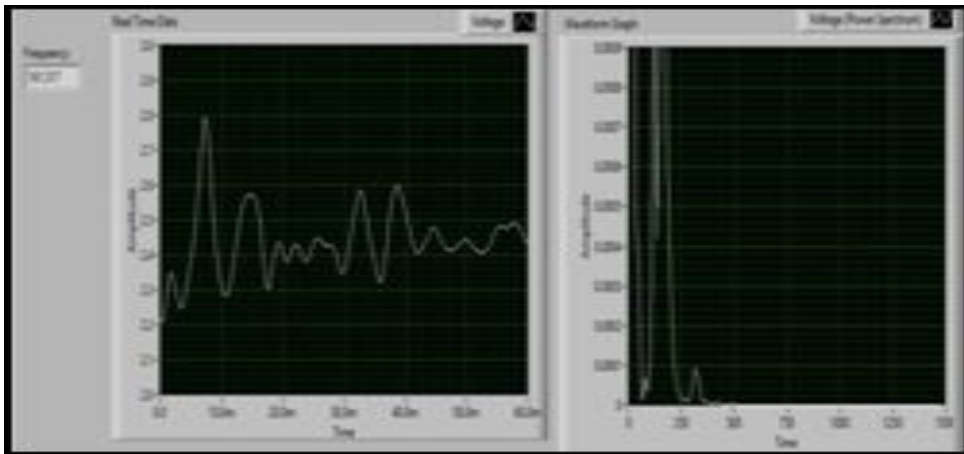

Figure 3: Simulation result for more than one human detected with different weights

4. CONCLUSION

Field testing showed that such measurement technology was capable of detecting the bottom intrusion in an underground system. According to the findings, the proposed method has the ability to discern the intensity and pattern of a standard intrusion load within a certain range.

Aside from the intrusion event's ability to be detected based on variations, The area of ground interruption can be derived from the temporal and spatial propagation qualities of vibration reactions along the passage in terms of vibration amplitude. Interferences from tram prepares and ground transportation were definitely not included in the research due to the accepted test time, which seems to be a weakness in the study that needs to be addressed. (Lili Wan et.al, Tiejun Chen et.al, 2009) However, since the load caused by the specific intrusion event is typically greater than that of the tiny excavator used in this paper, it is assumed that the proposed approach is often used to detect the bottom intrusion that occurs during the day.[7]

5. REFERENCES

- [1] Snehal Boob, Priyanka Jadhav, "Wireless Intrusion Detection System", International Journal of Computer Applications (0975-8887), Vol. 5, no. 8, August 2010, pp. 1-5.
- [2] Korcak, M., Lamer, J., & Jakab, F. (2014). Intrusion Prevention / Intrusion Detection System (IPS/IDS) For Wifi Networks. IJCNC, 6(4), 77-89.
- [3] Mosad Alkathami, Lubna Alazzawi, and Ali Elkateeb, "Border Surveillance And Intrusion Detection Using Wireless Sensor Networks", IJAET, Vol. 8, Issue 2, pp. 17-29, Apr 2015.
- [4] Vini Madan, S.R.N. Reddy, "GSM-Bluetooth based Distant Observing and framework with programmed Light Regulator", Worldwide Diary of PC applications (0975-8887), Vol. 46, no.1, May 2012.
- [5] P.M. Lange, K.L.G. Nielsen, "Phase acknowledgment in a working room utilizing sensor innovation", IT college of Copenhagen, Feb 2010. The Keen Identify Task Group, "Remote Sensor networks for Human Interloper Discovery", Indian organization of Science ,Bangalore, India, May 2010.

- [6] M.R. Eslaminejad, M. Sookhak, S.A. Razak, "A Survey of Steering Systems in Remote Sensor Organizations", *Global Diary of Software engineering and Telecom*, Vol. 2, no. 7, October 2011.
- [7] Lili Wan, Tiejun Chen, "Automobile Antitheft Framework Configuration dependent on GSM", *Global Meeting on Cutting edge PC Control*, Jan 2009, pp 551-554.
- [8] Mosad Alkhatami et.al., *Model and Techniques Analysis of Border Intrusion Detection Systems*, *Global Journal of Researches in Engineering: F Electrical and Electronics Engineering*, Volume 15 Issue 7 Version 1.0 Year 2015.
- [9] Aravindaguru I et.al., "An Automated Sensor System for Livestock Detection, Identification and Warning System based on the Ground Vibration in Cultivation Fields", *Bioscience Biotechnology Research Communication Special*, Issue Vol. 12, No (3), May 2019.
- [10] Kiruthika, S., Starbino, A.V., "Design and analysis of FIR filters using low power multiplier and full adder cells," *Proceedings - 2017 IEEE International Conference on Electrical, Instrumentation and Communication Engineering, ICEICE 2017*, 2017, 2017-December, pp.1-5.
- [11] S Kiruthika, P Sakthi, K Raam, G Sanjay, M Mohamed Rafi, "Vision Based Smart Parking System", *Turkish Journal Of Physiotherapy And Rehabilitation*, N; 32(2) Issn 2651-4451 | E-Issn 2651-446x, 2021.
- [12] S Kiruthika, "Monitoring Soil Quality and Fertigation System Using Iot", *Turkish Journal of Computer and Mathematics Education*, Vol. 12 No. 9 (2021)
- [13] K. Yasoda, R. Ponmagal, K. Bhuvaneshwari, and K. Venkatachalam, "Automatic detection and classification of EEG artifacts using fuzzy kernel SVM and wavelet ICA (WICA)," *Soft Computing*, vol. 24, no. 21, pp. 16011-16019, 2020.
- [14] C. Viji, N. Rajkumar, S. Suganthi, K. Venkatachalam, and S. Pandiyan, "An improved approach for automatic spine canal segmentation using probabilistic boosting tree (PBT) with fuzzy support vector machine," *Journal of Ambient Intelligence and Humanized Computing*, pp. 1-10, 2020.
- [15] K. Venkatachalam, A. Devipriya, J. Maniraj, M. Sivaram, A. Ambikapathy, and S. A. Iraj, "A novel method of motor imagery classification using eeg signal," *Artificial intelligence in medicine*, vol. 103, p. 101787, 2020.
- [16] S. K. Vasudevan, K. Venkatachalam, H. Shree, R. B. Keerthana, and G. Priyadarshini, "An intelligent and interactive AR-based location identifier for indoor navigation," *International Journal of Advanced Intelligence Paradigms*, vol. 15, no. 1, pp. 32-50, 2020.
- [17] S. Subramaniyan, R. Regan, T. Perumal, and K. Venkatachalam, "Semi-Supervised Machine Learning Algorithm for Predicting Diabetes Using Big Data Analytics," in *Business Intelligence for Enterprise Internet of Things*: Springer, 2020, pp. 139-149.
- [18] Punithavathani, D. Shalini, K. Sujatha, and J. Mark Jain. "Surveillance of anomaly and misuse in critical networks to counter insider threats using computational intelligence." *Cluster Computing* 18.1 (2015): 435-451.
- [19] Sujatha, K., and D. Shalini Punithavathani. "Optimized ensemble decision-based multi-focus imagefusion using binary genetic Grey-Wolf optimizer in camera sensor networks." *Multimedia Tools and Applications* 77.2 (2018): 1735-1759.
- [20] Chang, Jinping, Seifedine Nimer Kadry, and Sujatha Krishnamoorthy. "Review and synthesis of Big Data analytics and computing for smart sustainable cities." *IET Intelligent Transport Systems* (2020).
- [21] Song, Hesheng, and Carlos Enrique Montenegro-Marin. "Secure prediction and assessment of sports injuries using deep learning based convolutional neural

network." *Journal of Ambient Intelligence and Humanized Computing* 12.3 (2021):
3399-3410.