

Lifi Based Smart Library System

M.Jebakumari¹, R. Gowrishankar², R. Gowthamani³, C. Sunil⁴

^{1,2,3,4}Assistant Professor, Department of Computer Science and Engineering, Nehru Institute of Technology, Coimbatore

Email: nitjebakumari@nehrucolleges.com

Abstract: *The main problem during the data transfer is security. In early days various data transferring techniques has been used like wired data transfer, wireless data transfer, satellite based data transfer and etc. But each techniques having various drawbacks like security, data transfer rate, data loss and etc. As mentioned above, the most important problem is the security and data breaching. Also various researches have been still going on for secured data transfer. In case of high secured data transfer there are various limitations like, one to one communication or need one authorized person to validate the secured data. This makes more time consuming too. So these technologies are still in research. In order to overcome these problems, in this project Light Fidelity (Li-Fi) has been introduced. It is a new technique to transfer secured data using lights. For light via data transfer LED (Light emitting diode) has been used in both transmitting and receiving end. From one PC to another PC data can be transferred through light. In early research the light will blink and flash during the time of data transfer that may irritate to the user during the data transfer. Also the upload speed is not getting match with the download speed, so that low data transfer rate will occur. These problems are overcome in this system like, light will not flash during the time of data transmission, continuous light emission will be transfer the data. Also upload speed is equal to the download speed, through this method data transfer rate will be more high.*

Keywords: *Li-Fi, Digital Library, Visible light communication*

1. INTRODUCTION

The vast growth of wireless data traffic, which is expected to reach 49 Exabyte's by 2021 [1], motivates the usage of indoor lighting for both illumination and communication purposes. Light fidelity, widely known as Li-Fi, has been gaining attention from both academia and industry as a complementing technology for the existing radio frequency communication systems [2]. Li-Fi is high speed bi-directional networked and mobile communication of information exploitation lightweight. Li-Fi comprises of multiple light bulbs that form a wireless network, offering a substantially similar user experience to other wireless communication technology such as wireless fidelity (Wi-Fi) except it occupies the light spectrum. Li-Fi can potentially provide ubiquitous and high speed connections that employ off-the-shelf light emitting diodes (LEDs) and photodiodes (PDs) at the transmitter and receiver ends, respectively.

Applying li-fi in digital library;

Libraries have traditionally been known as the "House of writing", with the earliest library qualitative analysis back to 3200BC whereas fashionable library has dated back to the mid-20th century. A library homes data typically a collections of books, journals, manuscript,

artefacts and additional. To put it in a different way, it is “The Internet of old”, because a library was the only source of recorded information and resource back then.

Libraries such as The Snell Library of North-eastern University (below) have a dedicated media laboratory and digital creativity centre called the Digital Media Commons where Faculty, Staff and Students can engage in cooperative learning facilities such as; high-octane laptop workstations, 3D printers, professional-grade creation technology. All to boost learning and modify access to data. It is clear however so much libraries have evolved and also the edges of Digital libraries cannot be overemphasized, some of which are:

- Multiple usage/ access: Provides access to multiple users to leverage on various resources available in its database. It may generally even be on the market for users, over a distant geographical area with technologies such as e-libraries.
- Requires little space: We all know how much space books consumes, and the stress we go through having to walk round in search of a particular resource. Digital Libraries provides access at the press of a button effort enough physical area.
- Active 24/7: Because most libraries are managed by people they are bound to fall between working hours. Unlike Digital Libraries that may be accessible anytime and any day.
- Resource Preservation: Because physical libraries and resources are bound to certain factors that affect its durability. Much work must be worn out order to stay the state of such materials or resource. There is lesser concern on preservation and conservation once it involves Digital Libraries.
- Retrieval of Information: Digital Library and the technologies behind it allows for more accurate search and results in terms of information retrieval

It is therefore safe to say that although we cannot cancel out the papery background of the ‘Libraries of old’, Digital Libraries hold the potential to mould the minds of the present and future generations.

Here implementing light fidelity in digital library for easy accessing the files from library in an effective, fast and low cost manner.

2.LITERATURE SURVEY

Sixty years of research following Shannon’s pioneering paper has led to telecommunications solutions operating arbitrarily close to the channel Capacity VB flawless telepresence with zero error is available to anyone, anywhere, anytime across the globe [3].With the invention of diode (Light Emitting Diode), the concept of victimization lightweight as a communication medium has started once more.VLC uses white lightweight Emitting Diodes (LED), that send information by flashing lightweight at speeds undetectable to the human eye.One major advantage of VLC is that we will U.S.A. the infrastructure around us while not having to form any changes to that.LEDs’ ability to transfer information signals over light (light which is between 400THz to 800THz of frequency and whose wavelength is between 400nm to 700nm) makes it a very good communication medium.Now {the lightweight the sunshine} we have a tendency to use in our existence cannot solely be used for providing light however conjointly for communication.Upon elaborate investigation of VLC analysis, it had been found that not a great deal of analysis has been done to develop this technology for industrial use.But as a result of analysis into VLC is comparatively new, the chances are wide open.A lot of analysis is being done to form this technology offered for industrial use in varied fields, together with web access and vehicle-to-road communication victimization light lights.From our review of the literature, it became evident that job ought to be done to appear into the likelihood of coming up with a brand new model that might match thisinfrastructure for indoor applications [4].Demands for broadband wireless access services are expected to outstrip the spectrum capability within

the near-term “spectrum crunch.” Deploying further femto cells to handle this challenge is cost-inefficient due to the backhaul challenge and therefore the steep system maintenance. According to Associate in Nursing Alcatel–Lucent report, most mobile web access traffic happens inside. Leveraging power cable communication and therefore the offered indoor infrastructure, visible radiation communication (VLC) are often utilised with a tiny low one-time price. VLC conjointly facilitates the good advantage of having the ability to collectively perform illumination and communications, and small further power on the far side illumination is needed to empower communications, thus rendering wireless access with small power consumption. In this study, we investigate the problem of minimizing total power consumption of a general multiuser VLC indoor network while satisfying users’ traffic demands and maintaining an acceptable level of illumination. We utilize the column-generation method to obtain an ϵ -bounded solution. Several sensible implementation problems are integrated with the projected algorithmic program, including different configurations of light source and ways of resolving the interference among VLC links. Through intensive simulations, we have a tendency to show that our approach reduces the facility consumption of the progressive VLC-based planning algorithms by over 50% whereas maintaining the specified illumination [5].

3. PROPOSED SYSTEM

The visible light communication (VLC) refers to the communication technology which uses the visible light source as a signal transmitter, the air is used as the transmission medium, and the appropriate photodiode as a signal receiving component. Visible light should be considered as the medium for wireless transmission because it has got few advantages over other standard wireless transmissions. The main advantage is visible light’s frequency spectrum bandwidth, which ranges from 430 THz to 750 THz. The information measure is way larger than the oftenness information measure, that ranges from three kilocycles to three hundred gigacycles. With a larger bandwidth it is possible to accommodate more users and potentially achieve higher transfer rates because each one can give a larger portion of the bandwidth to transfer the information. The abundance is one of the other reason. Light sources are everywhere, and can be more efficiently used by increasing its simultaneous functionality by transmitting data in addition to lighting to a specific area. On working days, company buildings, restaurants etc. will have lights on for at least the duration of hours of operation, of which is used for VLC. TABLE 1 shows the characteristics of VLC over RF communication. Data transfer at intervals a system is mostly in parallel. All the bits of the data where transferred in parallel at the same instant from a digital system. In some cases, particularly in transferring data over long distances, it is preferred to transfer the data in serial form. The data word from a transmitting system is converted to stream of serial bits, and one bit is transferred on a single line to a receiving system at a time. At the receiving end, the data is reconstructed by serial to parallel conversion. The speed of data transmission in serial communication is specified by baud rates. Asynchronous data transfer is used for the serial communication which is done at a lower speed, typically at standard rates such as 2400, 4800, 9600, 19200 bauds etc. The synchronising clock or timing signal are not used in the asynchronous communication. LASER Communication is one of the fast growing area in wireless communication system. Due to its low noise magnitude relation makes it additional preferred communication medium for exchange of data. Currently LASER communication is used in satellite communication for space research because of its efficiency on low noise ratio, inexpensive, low power and its flexibility and the LASER communication doesn’t affect the radio noises. It made the LASER communication more preferable. In this process,

this paper deals with one such application of LASER communication for information exchange between any two devices

4. SYSTEM ARCHITECTURE

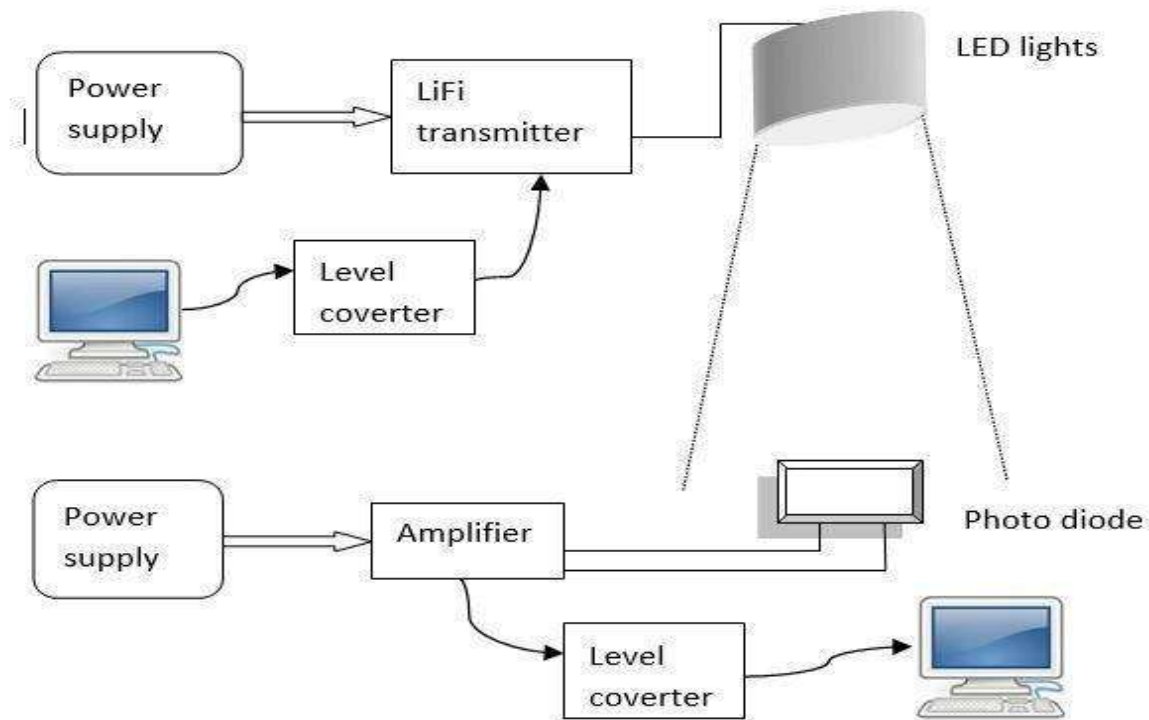

4.1 BASIC BLOCK DESCRIPTION

The circuit used for data transfer using visible light communication is mainly consisting of three sections. They are

1. Power Supply section.
2. Transmitter section.
3. Receiver section

4.2 POWER SUPPLY SECTION

Both the transmitter and the receiver section is operated in 5V DC. It is designed using the 7805 regulating IC. 1N4007 diode is used to make the bridge rectifier. The 780x series of fixed-voltage integrated-circuit voltage regulators are designed for a wide range of applications. These applications are regulation, elimination of noise and the distribution problems associated with single-point regulation. Each of these regulators can deliver up to 1.5 A of output current. The internal current-limiting and thermal-shutdown features of these regulators make them immune to overload. In addition to use as fixed-voltage regulators, these devices can be used with external components to obtain adjusted output voltages and currents, and also can be used as the power-pass element in precision regulators.

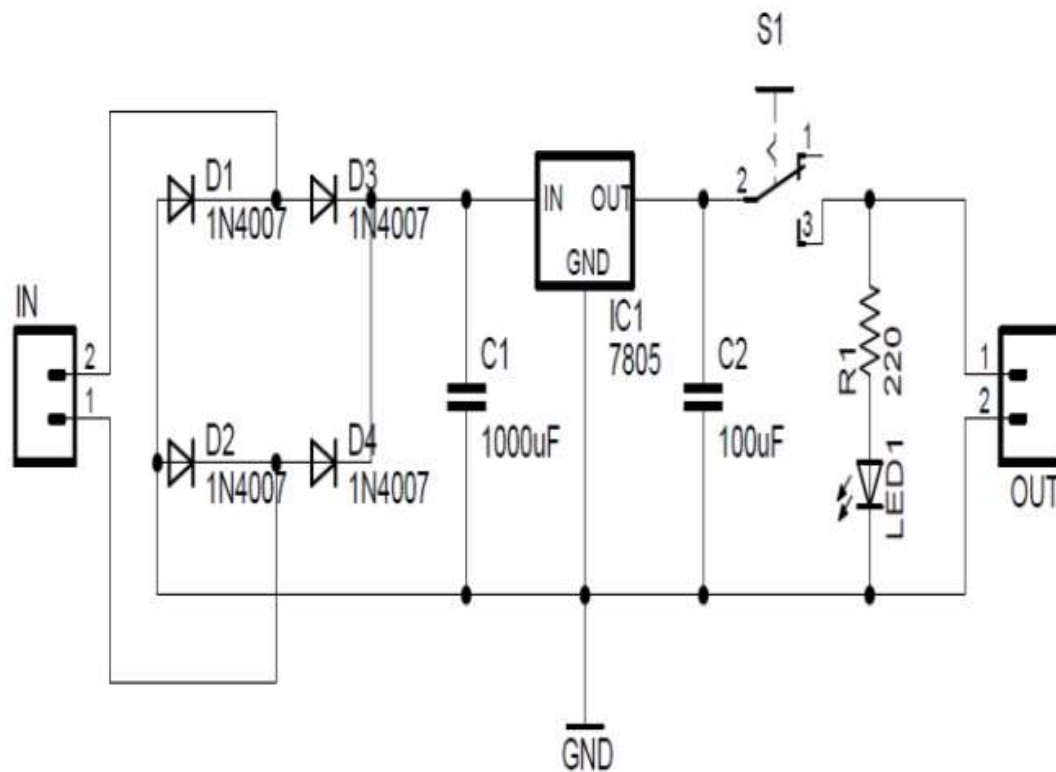

4.3 TRANSMITTER SECTION

The transmitter section is used for transmitting image data from the transmitter PC. It consists of several components.

They are

- a. Computer with HyperTerminal software
- b. Max 232 IC
- c. LASER switching circuit
- d. LASER diode

The main component in a transmitter section is the visible light source. The LASER is used as the light source to transmit the data transmission is performed using the serial communication technique of the computer. The serial port communication is performed to and fro using the RS 232 pin. For the easy and proper analysis, we transmitted an image from one PC to another. For the easy processing and manipulation of the data a software called Hyper terminal was used. LASER light is the main component in the transmitter section. Here a Normal a 650 nm 5V red dot LASER diode is used to transfer the data. In this study the data is changed to binary by using the MATLAB software and then transmitted. The output of the computer is taken using the serial communication port. As the modern computers and laptops have a serial output port, here used a USB to Serial port converter. The output of the computer is made to a constant output by using a MAX 232 IC. While the LASER is in ON condition, it's considered to be as 1 at the receiving end else 0. The driver circuit of the LASER is designed by using a BC 547.

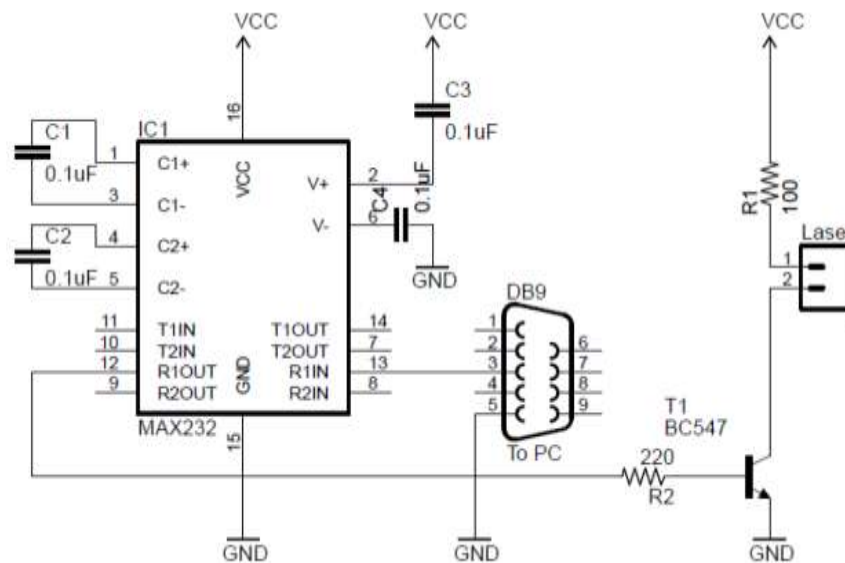

Working Principle

In this study, the serial communication is performed to transfer the data. This circuit is mainly consists of Max 232 IC. DB9 Pin receives the data towards the Max 232 IC. MAX 232 IC converts RS 232 logic input to TTL logic output which is used to drive the LASER diode. The data is transferred as binary data. Here the LASER diode is made on and off simultaneously according to the received input using switching circuit made by BC 547. While zero is received, the output of MAX 232 will be 0V, else 5V.

4.4 RECEIVER SECTION

The silicon photodiode is used as the receiver. The MAX 232 IC is used to convert the TTL logic to RS 232 logic. So that the computer can process the data.

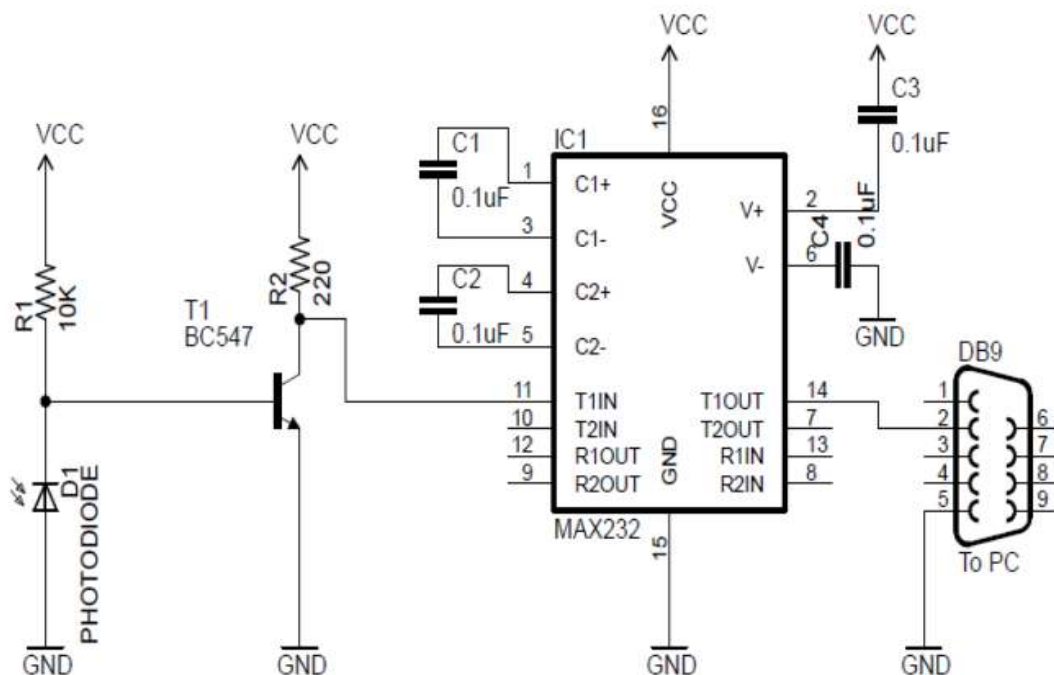

Working Principle

Photodiode is used as the receiver. The photodiode is directly connected towards the Max 232 IC to retrieve it into RS 232 logic. Then it is directly given to the computer. This input can be processed easily

5. IMPLEMENTATION

A Li-Fi based system to transfer data from one device to another using visible light. The proposed system consists of Li-Fi transmitter and receiver circuits with LEDs, photo-detector, MAX232A IC and inverter, battery, connecting wires and USB or COMM port. The sending device will select some data to the transmitter circuit of the sender's device. The LEDs in the transmitter circuit will transmit this data. The photo detector of the receiver circuit will receive this data from the light detected and will send it to the receiving device which will interpret and obtain the final data that was sent by the sender.

The proposed Li-Fi system will consist of the following modules:

- a) Graphical user interface
- b) Data reading module
- c) Data conversion module
- d) Transmitter module
- e) Receiver module
- f) Data interpreter module

The Data reading module reads data from the sender device and sends this data to the data conversion module. The data conversion module converts this data into suitable format, i.e. in the form of binary bits (byte format) so that it can be represented as a digital signal. Before converting this data into binary form, the data conversion module can also apply some encryption algorithm to encrypt the sender's data. The data is then sent to the transmitter module which generates the corresponding on-off pattern of the LEDs. In this way, data is sent from the sender. The Receiver module receives the data. The receiver module has a photo-diode to detect the on and off states of the LEDs. The receiver module captures this sequence and generates the binary sequence of the received signal. It then sends the binary sequence to the Data interpretation module which converts the data to the original format. If encryption was done at the sender, then Data interpretation module also performs decryption. It then sends the final result to the Data display module which displays the final received data to the receiver. In this way, the data is received by the receiver in a Li-Fi system.

LIGHT SOURCE

Light Source The most important requirement that a light source has to meet in order to serve communication purposes is the ability to be switched on and off repeatedly in very short intervals. By utilizing the advantage of fast switching characteristics of LED's compared with the conventional lightning, the LED illumination is used as a communication source. Since the illumination exists everywhere, it is expected that the LED illumination device will act as a lighting device and a communication transmitter simultaneously everywhere in a near future. Typically, red, green, and blue LEDs emit a band of spectrum, depending on the material system. The white LED draws much attention for the illumination devices. Comparing the LED illumination with the conventional illumination such as fluorescent lamps and incandescent bulbs, the LED illumination has many advantages such as high efficiency, environment-friendly manufacturing, design flexibility, long lifetime, and better spectrum performance. LEDs emit light when energy levels change in the semiconductor diode. This shift in energy generates photons, some of which are emitted as light. The specific wavelength of the light depends on the difference in energy levels as well

as the type of semiconductor material used to form the LED chip. Solid-state design allows LEDs to withstand shock, vibration, frequent switching (electrical on and off shock) and environmental (mechanical shocks) extremes without compromising their famous long life typically 100,000 hours or more. The basic LED consists of a semiconductor diode chip mounted in the reflector cup of a lead frame that is connected to electrical (wire bond) wires, and then encased in a solid epoxy lens. The architecture of LED is shown

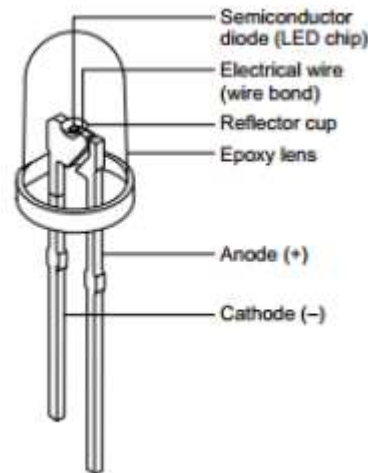

RECEIVER END

Receiver The receiving sensor is an NPN photo-transistor. Although the light wavelength is in the visible spectrum (~670nm) the photo-transistor's broad response band (550nm to 1050nm) is wide enough to sense the intense light beam. The signal from the photo-transistor is buffered via a pair of Schmitt trigger buffers to clean up and square the signal. The output of the second buffer is then directly converted to a RS-232 standard signal via an integrated circuit.

RS232: Standard Communication as defined in the RS232 standard is an asynchronous serial communication method. The word serial means, that the information is sent one bit at a time. Asynchronous tells us that the information is not sent in predefined time slots. Data transfer can start at any given time and it is the task of the receiver to detect when a message starts and ends. The RS232 standard describes a communication method where information is sent bit by bit on a physical channel. The information must be broken up in data words. The length of a data word is variable. On PC's a length between 5 and 8 bits can be selected. This length is the net information length of each word. For proper transfer additional bits are added for synchronization and error checking purposes. It is important, that the transmitter and receiver use the same number of bits. Otherwise, the data word may be misinterpreted, or not recognized at all. With RS232, the line voltage level can have two states. The on state is also known as mark, the off state as space. No other line states are possible. When the line is idle, it is kept in the mark state.

Software Details: The Data Reading module, Data interpretation module and the Data display (GUI) are implemented in software. The software performs the task of selection of data to be sent, reading the data to be sent and data conversion at the sender's side. First, the user selects the COMM port to which the Li-Fi circuit is connected and the other required settings for communication (Fig. 8). Then, the User interface appears which allows the user to communicate with the receiver and send text and image. The data to be sent is selected by the user and the software reads this data. Then, this data is converted into byte format so that it can be sent to the transmitter circuit. Encryption can also be performed on this data. If encryption is performed, then the cipher text is produced by the software which is converted

into binary form. Finally, this data is sent to the Transmitter circuit that transmits this data in the form of light.

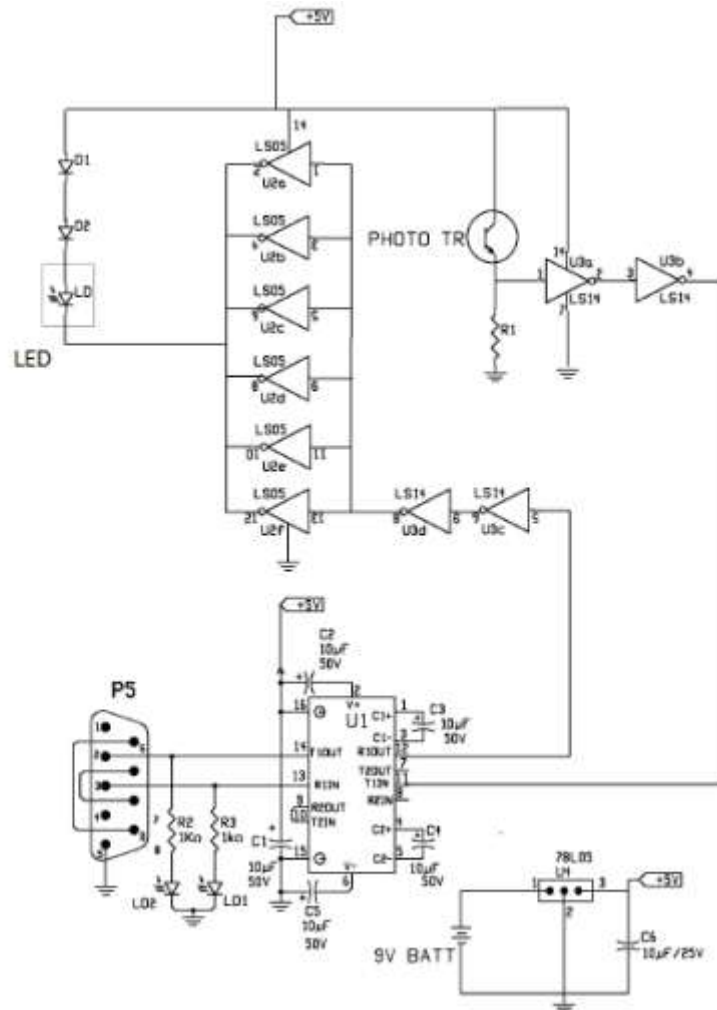

6. RESULT AND DISCUSSION

The Li-Fi system proposed in this paper is capable of transmitting data such as text, image, audio and video between two devices at the speed of a few kbps. The main requirement is line of sight between the sender and the receiver and hence it can be used to transmit data within a room.

Li-Fi technology is based on (Visible Light Communication) VLC technology. VLC is one of the advanced optical wireless communication technologies in which light in the visible region (375nm-780nm) is used as a medium for data transmission. It is more secure and achieves high data rates as compared to conventional wireless technologies like Wi-Fi, Bluetooth, Wi-max, etc. which use radio waves for communication Initially researchers were able to achieve network speed of about 100Kbps.

With continuous developments, VLC systems can now achieve about 800Mbps data rate for short range communications. Many companies and research institutes are conducting research to develop and commercialize Gigabit networks for long range communications. Reliability and network coverage are the major issues to be considered by the companies while providing VLC services. Interferences from external light sources like sun light, normal

bulbs, and opaque materials in the path of transmission will cause interruption in the communication. High installation costs of the VLC systems can be complemented by large-scale implementation of VLC. Adopting VLC technology will reduce further operating costs like electricity charges, maintenance charges, etc.

Li-Fi technology is still in the introductory phase. Indoor networking and location based services are the only applications that are quite penetrated in the market. Li-Fi may be implemented as a complementary technology to the existing wireless networks. It is expected to penetrate M2M communication, smart cities, power over Ethernet (PoE), wireless sensor networks, ubiquitous networks, augmented reality etc. Li-Fi relies heavily on these special LED light bulbs for data transmission. The market availability of these Li-Fi compliant LED bulbs is extremely important. In addition, the usability of these LED bulbs with current home electric wiring is another catalyst. The manufacturing and retail costs of LED are major factor for Internet Service Providers and customers wishing to switch from Wi-Fi to Li-Fi respectively. Personal computers and home entertainment devices in portable forms are an integral part in current households. Li-Fi technology can perform a critical role in providing super -fast home broadband speed that will allow higher bandwidth data communication on different platforms at the same time.

The concept of Li-Fi is attracting a great deal of interest because it may offer a genuine and very efficient alternative to radio-based wireless technology. If this technology is put into practical use, every bulb can be used like a Wi-Fi hotspot to transmit wireless data and the world will proceed towards a cleaner, greener, safer and brighter future. In future one can use micro LEDs for data transmission which flickers at a much higher rate than ordinary LEDs and in turn provides higher speed. A cluster of LEDs can be used for parallel data transmission. LEDs of different colours such as red, green and blue can be used to enhance the transmission rate.

7. CONCLUSION

We have investigated and analysed the performance of VLC system under dimming control scheme. To maintain the communication quality in terms of number of transmitted bits and a BER of less than 10^{-3} , the data rate has to be increased when the duty cycle of PWM dimming control signal is reduced, i.e., the LED light is dimming. In the OOK VLC system, when the duty cycle is smaller than 0.3, on the one hand the data rate has to be increased largely, which makes it difficult to be implemented on the original circuit; on the other hand, the required LED lamp power to achieve BER of 10^{-3} for the whole range of duty cycle also has to be increased significantly, which is power-consuming. To solve the problem, we have proposed to apply the variable M-QAM OFDM to VLC systems, where the M is changed firstly according to the duty cycle, followed by adjusting the symbol rate. Results have shown that the required symbol rates are always not larger than the original symbol rate and larger than half of the original symbol rate, which guarantees the communication quality as well as makes the dimming control scheme easy to be implemented in the real VLC system. In addition, the required LED lamp power to achieve BER of 10^{-3} is much less than that of OOK signal, which is power-saving.

9. REFERENCES

- [1] International Journal of Applied Engineering Research, ISSN 0973-4562 Vol.7 No.11 (2012)

- [2] International Journal of Electronics and Electrical Engineering Vol. 1, No. 4, December, 2013.
- [3] International Journal of Engineering Trends and Technology (IJETT) – Volume 13 Number 3 – Jul 2014
- [4] Proceedings of the 1999 IEEE Industry Applications Society Conference Phoenix, Arizona, USA, October 3-7, 1999
- [5] IEEE JOURNAL ON SELECTED AREAS IN COMMUNICATIONS, VOL. 27, NO. 9, DECEMBER 2009
- [6] ISSN: 2277-3754 ISO 9001:2008 Certified International Journal of Engineering and Innovative Technology (IJEIT) Volume 3, Issue 12, June 2014
- [7] Komine and M. Nakagawa, “Fundamental analysis for visible light communication system using LED lights,” IEEE Trans. On consumer electronics, vol. 50,pp. 100-107,2004.